

EVOLUTION FROM CELLULAR  
TO SOCIAL SCALES. NATO  
ADVANCED STUDY  
INSTITUTE.  
GEILO, NORWAY,  
10 – 20 APRIL 2007:  
POSTER ABSTRACTS



Address	<b>KJELLER</b> NO-2027 Kjeller, Norway	<b>HALDEN</b> NO-1751 Halden, Norway	
Telephone	+47 63 80 60 00	+47 69 21 22 00	
Telefax	+47 63 81 63 56	+47 69 21 22 01	
Report number	<b>IFE/KR/E-2009/001</b>		Date 2009-05-27
Report title and subtitle	Evolution from Cellular to Social Scales		Number of pages 41
Project/Contract no. and name	Geiloskolen		ISSN 0333-2039
Client/Sponsor Organisation and reference	NATO Scientific Affairs Division		ISBN 978-82-7017-789-9 (printed) 978-82-7017-790-5 (electronic)
Abstract	<p>Evolution is a critical challenge for many areas of science, technology and development of society. Emerging areas of science such as "systems biology" and "bio-complexity" are founded on the idea that phenomena need to be understood in the context of highly interactive processes operating at different levels and on different scales. Similarly, there is an increasingly urgent need to understand and predict the evolutionary behavior of highly interacting man-made systems, in areas such as communications and transport, which permeate the modern world. The same applies to the evolution of human networks such as social, political and financial systems, where technology has tended to vastly increase both the complexity and speed of interaction, which is sometimes effectively instantaneous. Better understanding, appreciation and prediction of the behavior of such systems will require the development of tractable methods for addressing evolution.</p>		
Keywords:			
	Name	Date	Signature
Author(s)	Trine Løkseth	2009-05-27	
Reviewed by	Geir Helgesen	2009-05-27	
Approved by	Arne Skjeltnor	2009-05-27	

## **Contents**

---

<b>1</b>	<b>Introduction</b>	<b>2</b>
<b>2</b>	<b>Programme</b>	<b>3</b>
<b>3</b>	<b>Poster Abstracts</b>	<b>5</b>
<b>4</b>	<b>Participants</b>	<b>31</b>

## 1 Introduction

This nineteenth ASI Geilo School in Norway since 1971 brought together researchers with various interests and background including theoretical physicists, soft condensed matter experimentalists, biological physicists, molecular biologists and social scientists to identify and discuss areas where synergism between modern physics, biology and social sciences could be most fruitfully applied to the study of various aspects of evolution.

Evolution is a critical challenge for many areas of science, technology and development of society. Emerging areas of science such as "systems biology" and "bio-complexity" are founded on the idea that phenomena need to be understood in the context of highly interactive processes operating at different levels and on different scales. Similarly, there is an increasingly urgent need to understand and predict the evolutionary behavior of highly interacting man-made systems, in areas such as communications and transport, which permeate the modern world. The same applies to the evolution of human networks such as social, political and financial systems, where technology has tended to vastly increase both the complexity and speed of interaction, which is sometimes effectively instantaneous. Better understanding, appreciation and prediction of the behavior of such systems will require the development of tractable methods for addressing evolution. On one hand, this implies deep analysis of particular evolutionary systems. On the other, there is clearly a need to develop general methods of analysis by investigating the similarities and commonalities between evolutionary systems in diverse areas in order to understand, for example, the phenomena in terrorist networks that are common to all networks, or at least to a large class of networks. Many fields of research are confronted with responses to evolutionary pressure in networks. Genetic and metabolic networks have evolved as a result of the interactions of proteins, substrates and genes in a cell. Social networks quantify the interactions between people in the society. Ecological systems are best described as a web of species, and terrorist networks have evolved through political and market pressures. The Internet is a complex web of computers increasingly used by terrorists and increasingly vital to almost all human activities. In many cases the interacting networks manifest regulation and adaptation and so-called emergent properties that are not possessed by any of the individual components. This means that the detailed knowledge of the components is insufficient to describe the whole system.

The motivation for this ASI was to bring together researchers with various interests and background including theoretical physicists in biology and econophysics, soft condensed matter experimentalists, biological physicists, molecular biologists, social scientists and computer scientists to identify and discuss areas where synergism between modern physics and biology may be most fruitfully applied to the study of network evolution, from cellular to social scales. The starting point in the ASI was a thorough discussion of general evolutionary facts like origin of life and evolution of the genome and clues to evolution through simple systems. This is where physics meets complexity in nature, and where we must begin to learn about complexity if we are to understand it. The next focus was on evolution at different scales and evolution of complex networks in nature and society. Finally, focus was on the possible universality of network structures and how this knowledge can be combined to attack the urgent problem of counter threats of security and terrorism.

The NATO ASI format in Geilo proved very efficient in getting researchers in different areas together and focus on the underlying theme that was common to all of them - that of networks and bioprocesses. In this manner, a rapid communication was possible because a common vocabulary was developed during the ASI.

The scientific content of the ASI Geilo School was timely and the resulting proceedings should provide a useful definition of the current status.

## 2 Programme

### 1st Day (Tuesday, 10 April)

- p.m. 14.30-18.00 Communal transportation from Oslo airport and Oslo to Geilo  
 18.30-19.30 Registration  
 19.30-20.00 Reception  
 20.00-21.00 Dinner  
 21.30-22.00 Arne T. Skjeltnor: Opening

### 2nd Day (Wednesday, 11 April)

- a.m. 08.30-10.30 Kim Sneppen: Introduction and perspectives to evolution  
 10.30-11.30 Joel Stavans: Keynote and lectures  
 Sex and Sensitivity  
 The (In)fidelity of Homologous Recombination  
 p.m. 15.30-17.30 Joel Stavans: Sex and Sensitivity  
 The (In)fidelity of Homologous Recombination (ctd.)  
 17.30-18.30 Author-attended posters (Group 1). Posters should be left on display until Saturday 14 April for informal discussions

### 3rd Day (Thursday, 12 April)

- a.m. 08.30-11.30 Richard Lenski: Experimental evolution: bugs and bytes  
 p.m. 15.30-17.30 Christoph Hauert: Evolutionary dynamics and the problem of cooperation  
 17.30-18.30 Tutorial group meetings and informal discussions with lecturers

### 4th Day (Friday, 13 April)

- a.m. 08.30-09.30 Christoph Hauert: Evolutionary dynamics and the problem of cooperation (ctd.)  
 09.30-11.30 Sine Lo Svenningsen: Small RNA control of quorum sensing  
 p.m. 15.30-17.30 Johan Paulsson: A) How evolution shapes control circuits: cost-efficiency of feedback control  
 17.30-18.30 Tutorial group meetings and informal discussions with lecturers

### 5th Day (Saturday, 14 April)

- a.m. 08.30-09.30 Mogens Hoegh Jensen: Dynamical genetic regulation  
 09.30-10.30 Sandeep Krishna: Network Models of Phage-Bacteria Co-Evolution  
 10.30-11.30 Ala Trusina: Similarities and differences in mammalian and yeast Unfolded Protein Response  
 p.m. 15.30-16.30 Johan Paulsson: B) How control circuits shape evolution: multileveled selection  
 16.30-17.30 Mikhail Ostrovsky: Evolution of vision  
 17.30-18.30 Tutorial group meetings and informal discussions with lecturers

### 6th Day (Sunday, 15 April)

- a.m. Free  
 p.m. 17.30-18.30 Author-attended posters (Group 2) Posters should be left on display until Thursday 19 April for informal discussions

### 7th Day (Monday, 16 April)

- a.m. 08.30-11.30 Vadim Agol: The origin and evolution of viruses  
 p.m. 15.30-17.30 Johannes Berg: Bayesian Analysis of Biological Networks: Clusters, Motifs, and Cross-Species Correlations  
 17.30-18.30 Tutorial group meetings and informal discussions with lecturers

**8<sup>th</sup> Day (Tuesday, 17 April)**

- a.m.** 08.30-09.30 Johannes Berg: Bayesian Analysis of Biological Networks: Clusters, Motifs, and Cross-Species Correlations (ctd.)  
09.30-11.30 Morten Kloster: Simple systems: dynamics of asexual evolution
- p.m.** 15.30-16.30 Morten Kloster: Simple systems: dynamics of asexual evolution (ctd.)  
16.30-17.30 David Sherrington: Network growth models (Tentative)  
17.30-18.30 Tutorial group meetings and informal discussions with lecturers

**9<sup>th</sup> Day (Wednesday, 18 April)**

- a.m.** 08.30-10.30 Joseph McCauley: Evolution of financial markets and our ideas of financial markets.  
10.30-11.30 Jarle Breivik: Genetic instability and the evolutionary dynamics of cancer
- p.m.** 15.30-16.30 Jarle Breivik: Genetic instability and the evolutionary dynamics of cancer (ctd)  
16.30-17.30 Ivar Giaever: The Nobel Prize and the Future of Science (?)  
17.30-18.30 Tutorial group meetings and informal discussions with lecturers

**10<sup>th</sup> Day (Thursday, 19 April)**

- a.m.** 08.30-11.30 Vladimir Skulachev: Biological aging as an evolutionary invention. Can the aging program be switched off?
- p.m.** 15.30-17.30 Brynjar Lia: Evolution of jihadist networks  
17.30-18.30 Tutorial group meetings and informal discussions with lecturers  
19:30 Geilo School Closing Dinner (Geilo Awards etc.)

**11<sup>th</sup> Day (Friday, 20 April)**

- a.m.** 08.30-09.15 Harry Thomas: Summary. Questions and discussions
- p.m.** 09.30-13.30 (approx.) Communal transportation of participants to Oslo for departure

Coffee breaks approximately 10.30 and 16.30

Lecturers should normally plan to have some short breaks every hour

### 3 Poster Abstracts

#### **Darwin on a chip: Laboratory evolution of new enzyme function using drop-based microfluidics.**

Jeremy Agresti,

*Harvard University Division of Engineering and Applied Sciences  
40 Oxford St. Cambridge, MA 02138, USA*

#### **ABSTRACT**

We are developing a completely *in vitro* system for the laboratory evolution of enzymes. To do this, we are designing tools to make and manipulate the aqueous drops of monodisperse water-in-oil emulsions on microfluidic devices. Each ~10 micrometer diameter water drop acts as an individual picoliter-volume reaction vessel, and we are able to make and analyze and manipulate millions of drops, and thus enzyme variants, per hour all on a device the size of a microscope slide. Because the system doesn't rely on living cells to produce the enzyme, we have much greater flexibility in choosing the conditions under which we perform the selections compared to traditional methods that rely on living cells. This should allow us to evolve new enzymes with tailor-made functions for a variety of applications. Here we will present the microfluidic modules we have developed to split, recombine, and sort drops, and also results selecting enzyme libraries for beta-galactosidase activity.

## $\lambda$ -phage Lysis-Lysogeny Decision – A Counting Game?

Mikkel Avlund, Sandeep Krishna, Ian Dodd , Kim Sneppen.

*Center for Models of Life, Niels Bohr Institutet, Copenhagen, Denmark*

### ABSTRACT

The lysis-lysogeny decision of phage  $\lambda$  has been studied for decades, but has not yet been fully understood. Though intrinsically stochastic, results by Kourilsky indicate the decision to be largely governed by a deterministic count of the number of simultaneously infecting phages. We construct a minimal phage network which can do such counting, and in addition fulfill the requirements that the lambda phage does. We find that this can be largely achieved using only two regulatory molecules, but at the cost of fast degradation rates and thus loose of sensitivity to RecA activity and SOS induction. We conclude that the extended regulatory network of lambda is associated to regulations of timescales in the infection process.



## Expression of Cu-transporting genes in liver of the rat fed with silver ions.

P.Babich, S.Klotchenko, K.Solovyov

*Saint-Petersburg State Polytechnical University;  
Research Institute of Experimental Medicine, St. Petersburg, Russia*

### ABSTRACT

One of the advancing fields of anticancer treatment is using platinum (cisplatin, carboplatin, oxaliplatin) and copper (diethyl dithiocarbamate-Cu(II), and Cu(II)-thioxotriazole) complexes, which induce of tissue specific apoptosis. Cellular mechanisms for the uptake, intracellular distribution and efflux of these drugs are unknown. Current data suggest that Cu-transporters mediate the transfer of these drugs across the cellular membranes (*Safaei, 2006*). The first of them is CTR1, plasma membrane high affinity copper importer (*Ctrl, Entrez SLC31A1*). The second is Cu-transporting ATPase P1 type (*Entrez ATP7B, Wilson ATPase*). ATP7B includes copper ions into molecular of ceruloplasmin (Cp), a main copper-containing extracellular protein, and thus excreted copper. Moreover Cp, which is the main copper donor for extrahepatic cells, can induce apoptosis. In cultured cells and tumor samples, a correlation was found between the expression of CTR1 and ATP7B and the degree of the acquired resistance to these drugs suggests that the Cu transporters are important constituents of the program that regulates sensitivity to drugs.

As a rule the drug transport mechanism is studied using cultured cells, and a model for studying drug transport *in vivo* does not exist. We are trying to develop such model. In the first stage we carried out expression Cu-transporting genes in liver of Wistar rats, which take up 50 mg of AgNO<sub>3</sub>/1 kg body weight with food during 2 weeks. It is known that such method allows simulating of copper deficiency (*Shavlovski, et al., 1995*). The obtained results shown that Cp oxidase activity of serum dropped to 30 times (35.5 mg/100 ml in control *versus* 1 mg/100 ml in experimental group). Simultaneously, Cp protein concentration, determined by semi quantities immunoblotting with specific antibodies, didn't change. In serum of experimental rats, copper concentration decreased to 10 fold, iron concentration increased to 2 fold, and zinc and silver didn't shift. The level of CTR1, Cp, and ATP7B genes activity was determined by semi quantities RT-PCR analysis. This data shown that activity of these genes was not change. Thus, Ag-feeding not effect copper transporting gene expression, but at the same time it decrease body copper concentration and prevent copper including into cuproenzymes. Such situation *in vivo* can be suitable for study of drug transfer mechanism.

## **Towards modeling multicellular tumor spheroids growth: Inverse geometric approach**

B. Brutovsky, D. Horvath and V. Lisy

*University of P.J. Šafárik in Košice, Slovak Republic*

### **ABSTRACT**

Genetic algorithms are used to find the transition rules of the cellular automata model reproducing the prescribed features, such as the velocity of the growth and fractal behavior of the multicellular spheroids contours. The required properties of the growth are formalized and implemented into the objective function expressing how well these requirements are fulfilled, i. e. the quality of the proposed solution, and the rules producing as low as possible value of the objective function are looked for. The approach enables to reproduce some of recent findings in the morphometric analysis of real tumors with the possible implications for cancer research.

## Evolution of Novel Substrate Activity in Bacterial Enzymes

H.Carpenter

*Emory University, Sycamore, Georgia, USA*

### ABSTRACT

Proline residues, or non-canonical imino acid analogues can have a critical effect on the structural and functional properties of proteins. We have developed a system for the multiple site-specific incorporation of proline analogues into elastin-mimetic polypeptides using a genetic engineering approach. The inherent codon bias observed for an *Escherichia coli* bacterial cell host can be exploited to create an orthogonal prolyl-tRNA synthetase/prolyl-tRNA pair that decodes the rarely utilized proline CCC codon. The ProRS/tRNA<sup>Pro</sup> pair from *M. jannaschii* was shown to be orthogonal to the native *E. coli* translational machinery. This pair could be used to capture the rarely used CCC codon, which was introduced at positions encoding proline residues in a synthetic elastin-mimetic protein. We hypothesize that this *in vivo* approach might be employed to control protein structure through the site-specific incorporation of imino acid analogues, which would enable the creation of novel protein-based materials.

## Sample size effects in photoexcitation of biological molecules

M. V. Olenchuk<sup>a</sup>, Yu. M. Barabash<sup>a</sup>, V. N. Kharkyanen<sup>a</sup>, and L. N. Christophorov<sup>b</sup>

<sup>a</sup>*Institute of Physics, NAS Ukraine, Kiev, Ukraine*

<sup>b</sup>*Bogolyubov Institute for Theoretical Physics, NAS Ukraine, Kiev, Ukraine*

### ABSTRACT

Many photoactive biological molecules possess functional excited states with lifetimes much longer than typical decay times  $\approx 10^{-8}$  s, even exceeding seconds in some cases. Such states are observed, for example, in functional cycles of photosynthetic reaction centres (RCs), bacteriorhodopsin (BRh), photoactive yellow protein (PYP) and others, arising due to relaxation of the first photoexcited singlet to a charge transfer state (as in the RC), or due to structural rearrangements in the vicinity of the excited molecular group (as in BRh or PYP), or due to both these processes. It is well known that in such cases the classical Bouguer-Lambert-Beer law is violated since the concentration of molecules in the ground state does not coincide with their total concentration any longer and, in general, changes along the light propagation path. Obviously, such nonlinear effects can have a noticeable influence upon the values of the main kinetic parameters determined by means of optical spectroscopy. Actually, it is the situation that often takes place in experimental studies of samples of real sizes.

We develop a theory taking into account these deviations from the BLB law for both steady and non-stationary regimes of light propagation in the sample. Results are applied to investigation of the electron transfer processes in bacterial RCs, essentially improving the methodology of determination of their main kinetic parameters.

## **Investigation of phenotype changes in cyanobacteria, induced by spontaneous genetic mutations.**

E.V. Dubrovin, I.A. Kirik, M.M. Babykin, I.V. Yaminsky

*Moscow State University, Moscow, 119992, Russia*

### **ABSTRACT**

In this work atomic force microscopy (AFM) was used to study two different strains of the unicellular cyanobacterium *Synechocystis* sp. PCC 6803: motile (wild type) and non-motile (spontaneous mutant) strains. As known the *Synechocystis* 6803 wild type cells produce pili of two morphotypes distinguished by diameter, length, morphology and relative abundance. Thick pili (one morphotype) are identified with well-known bacterial type IV pili responsible for cell gliding motility; the function of thin pili (another morphotype) is still unknown. AFM has revealed differences in piliation of the motile and non-motile strains of the cyanobacterium and allowed estimating real dimensions and quantity of pili. According to the data obtained non-motile mutant cells possess thick pili increased in number (to 3-5 times) and length (more than to 10 times) relative to the wild type cells, however, both strains do not differ in thin pili.

## EVOLUTION OF SOCIAL COMPLEX SYSTEMS GOVERNED BY KINETIC EQUATIONS IN FRAMEWORK OF QUASI-EQUILIBRIUM STATISTICAL LAWS

Vitalie Eremeev<sup>1,2</sup>, Florentin Paladi<sup>2</sup>

<sup>1</sup>*Institute of Applied Physics, Academy of Sciences of Moldova,  
Academiei str. 5, Chisinau MD-2028, Republic of Moldova*

<sup>2</sup>*Department of Informatics and Engineering, Free International University of Moldova, V.Parcalab str. 52, Chisinau MD-2012, Republic of Moldova*

### ABSTRACT

Physics has a great experience in studying of many-body system and complex system and here is established the apparatus of fundamental deterministic or statistical laws and principles. These laws are able to explain the real behavior of any classical system or even quantum system. On the other hand, the sciences which study the behavior of diversified non-physical complex systems have a deficit concerning the laws or theoretical models that would be in good agreement with experimental or forecasted data. In this consecution of idea, it is interesting to establish some fundamental similarities between the physical (natural) systems and non-physical systems in order to find universal laws under which is approached any complex system.

The concepts and methods such as ensemble statistics, correlation and self-correlation analysis have been widely used to describe the property of the social phenomena. For example, a power law is usually related with critical phenomena in physics, including critical point of equilibrium and non-equilibrium phase transition. Also as pointed in [1-3], relation between variation and size of system's components imply the form of interaction. When a universal law is found for different systems, the systems must be equivalent in some ways. So it implies common mechanism and others can be understood if we know one of them very well. Therefore, it open a new way to investigate such systems, especially when some models with similar properties in physics and other fields can be used here as a reference model for social phenomena as an example.

We propose to study the evolution of social complex systems by kinetic equations which describe the quasi-equilibrium statistical processes. Thus is assumed to generalize the model discussed in [3] that is developed on the basis of cluster theory and used to simulate the dynamics of the complex systems, composed from a number of interacting agents, with different sizes. Also we will emphasize how the proposed master equation can be approachable using the Boltzmann kinetic equation applicable for transport phenomena in statistical mechanics. The possibility to describe the stochastic dynamics of social system in the formalism of Fokker-Planck equations is discussed too.

Our results support the idea that the extremely fascinating universal aspects observed in the empirical analysis of finance fluctuations and economic organizations, i.e. the empirically observed power law distributions, can really arise from interplay between random growth and the complex structure of the system.

[1] L.A.N. Amaral, S.V. Buldyrev, S. Havlin, M.A. Salinger and H.E. Stanley, *Phys.Rev.Lett* **80**, 1385 (1998).

[2] A. Dragulescu, cond-mat/0307341 based on PhD thesis.

[3] F. Paladi, V. Eremeev, *Physica A* **348** (2005) 630-640.

## Does Partial Recapitulation occur in the development of human heart ?

Azize Yasemin Göksu<sup>1</sup>, Hüseyin Göksu<sup>2</sup> and Mehmet Salih Arıkan<sup>3</sup>

<sup>1</sup>Department of Medical Genetics, Süleyman Demirel University School of Medicine, Isparta, 32260, Turkey

<sup>2</sup>Department of Electrical and Electronics Engineering, Akdeniz University, Antalya, 07058, Turkey

<sup>3</sup>Department of Microbiology&Clinical Microbiology, Süleyman Demirel University School of Medicine, Isparta, 32260, Turkey

### ABSTRACT

The hypothesis that ontogeny recapitulates phylogeny suggests that an animal's embryologic development repeats the evolutionary development of the species. It is obvious that exact recapitulation does not exist. But if we look at organogenesis, we see signs of recapitulation. One striking manifestation of this is the development of the cardiovascular system which shows conserved developmental modules through different species.

The hearts of nonmammalian vertebrates are very similar to embryologic forms of mammalian hearts. In amphioxus or fish etc., the development of heart ceases in earlier stages. So, we may correlate the evolutionary stage of fish heart with single atrium and ventricle to the early embryonic stage of human heart during 4-5 weeks of gestation. If we suggest that the heart of a human embryo shows equivalency/similarity with the heart of grown-up members of certain species, e.g. heart of a fish, there is a possibility of equivalency/similarity in their cardiac regulatory gene expression at that stage.

Data show that continuous adaptation of the genomic regulatory programs that control cardiac development accompanied the evolution of species. Moreover, the heart formation in different species is controlled by an evolutionarily conserved network of transcription factors, which connect signaling pathways to genes. During evolution, this ancestral gene network was expanded through gene duplication and co-option of additional networks. The numbers of expressed cardiac regulatory genes are found to be increased as the cardiac structures become more complex in organisms from cnidaria to humans. As an example; the numbers of core cardiac transcription factors NK2, MEF2, GATA, Tbx, and Hand are found to be as follows for ascidians and mammals; 1, 1, 2,  $\geq 3$ , 1 and  $\geq 2$ , 4, 3,  $\geq 7$ , 2, respectively. During human embryogenesis, a single tubular cardiac structure develops into a four chambered heart in association with the expression of many types and subtypes of transcription factors.

Defining both the similarities and differences among the vertebrate model systems can provide insight to normal human development and pathophysiology. As an example, the zebrafish is a powerful model system for understanding the function and regulation of transcription factors. This may highlight the genetic network for organogenesis of species by bidirectional matching. On the other hand, mutations in components of the cardiac gene network cause congenital heart diseases. The consequences of such mutations reveal the evolutionary origins of morphological complexity. Ancestral cardiac network of transcriptional factors may provide a unique perspective into disturbed cardiac embryologic development. If ontogeny recapitulates phylogeny partially in the level of organogenesis, the knowledge of pattern and timing of the expression of cardiac regulatory genes during embryologic development, and mutational analysis of cardiac defects may provide further insight into the evolution of the heart. Furthermore, human cardiac development in terms of transcription factors may be realized by studying the hearts of nonmammalian vertebrates.

## Hormonal Regulation of Biological Processes

Hakobyan N.R.

*Department of Biophysics, Faculty of Biology, Yerevan State University, Yerevan, Armenia*

### ABSTRACT

Cooption and modularity are informative concepts in evolutionary developmental biology. Genes function within complex networks that act as modules in development. These modules can then be coopted in various functional and evolutionary contexts. Hormonal signaling has a modular character. By regulating the activities of genes, proteins and other cellular molecules, a hormonal signal can have major effects on physiological and ontogenetic processes within and across tissues over a wide spatial and temporal scale [2]. Hormones play key roles in the regulation of animal and plant life histories, particularly in the timing of transitions between prematurational stages and in the scheduling of reproduction. Furthermore, hormonal mechanisms are subject to information about the external and internal environment of the individual. Within an evolutionary radiation, the same hormone subsets often regulate the schedules of development as well as adult reproduction and related activities and, moreover, are involved in mechanisms of senescence [1].

Because of this property, we argue that hormones are frequently involved in the coordination of life history transitions and their evolution [2].

### References

1. Finch CE, Rose MR. Hormones and the physiological architecture of life history evolution. //Q Rev Biol. 1995 Mar; 70(1):1-52.
2. Heyland A, Hodin J, Reitzel AM. Hormone signaling in evolution and development: a non-model system approach. // Bioessays. 2005 Jan; 27(1): 64-75



## **Studying fine effects of magnetic processing water on developmental processes in living systems**

Medvedeva A.A., Volkov Yu.V.

*Moscow State University, Dept. of developmental biology*

### **ABSTRACT**

Currently, evolution of biosphere is a result of transformations in nature and human activity. As for water pollution, changes happen at structural and informational levels. The influence of ordinary pollutant is well-known. But even weak effects eventually can cause pronounced modifications of structure and functional characteristics of water. The developing organism is an ultrasensitive instrument for detection of such weak external effects. The experimental objects under investigation (fish and frog embryos) allowed estimating influence of magnetic processing of water on the course of embryogenesis and its final result –adult stage.

In present research we used water after having it magnetically processed in different ways (maintaining in strong and weak constant magnetic fields, choosing either N or S magnetic poles) and observed the process of development in living organisms immersed into it.

While studying physical properties of water fluidity, viscosity and superficial tension are most interesting since these properties are important for its passage through membranes and capillaries [1, 2] and, as a consequence, for intercellular and intracellular processes in biological systems. We used the following parameters while assessing effects of magnetic processing of water on embryogenesis:

- mortality
- quantity and quality of malformations
- rate of developmental processes (ranging embryos into developmental stages at certain time)

Initially it was expected (based on published data) that S-polarity accelerates the development and N-polarity slows it down. The experiments proved that this is true only in a certain range of induction.

Mixing water processed at N and S poles positively affects developing fish and amphibian embryos, reduces death and accelerates the transition of embryonic stages. Practical control of water properties gives prospects of purposeful regulation of rates of various processes in biological objects.

1. Volkov Yu.V., Medvedeva A.A. Natural and technical science, 2006.
2. Zuravlev A.I. Basics of physics and biophysics. Moscow, Mir, 2005.

## Theoretical analysis of epigenetic cell memory by nucleosome Modification

Mille A. Micheelsen

*Niels Bohr Institute, Copenhagen, Denmark*

### ABSTRACT

The expression of genes in eukaryotic cells can be regulated by the chromatin in which they are embedded. Long chromosomal regions can adopt persistent and heritable silenced or active states, often associated with alternative chemical modifications (e.g. methylation and acetylation) of the nucleosomal histones that package the DNA. Stability and heritability of these states is thought to involve positive feedback loops where the modified nucleosomes recruit the enzymes that perform the modifications. A canonical case is the bistable expression of genes in the mating-type region of a mutant of the yeast *Schizosaccharomyces pombe*. Here we suggest a simplified model of such a system and demonstrate that it can give strong two-state behaviour that can tolerate high levels of noise in nucleosome modification. Dynamic bistability requires the recruitment feedback loop to be non-local and directly or indirectly cooperative - modification must be aided by more than one non-neighbouring nucleosome. We also show that bistability can be robust to a random partitioning associated with DNA replication.

## Efficient degradation and sorting with small RNAs

Namiko Mitarai, Anna M. C. Andersson, Sandeep Krishna, Szabolcs Semsey,  
and Kim Sneppen

*Niels Bohr Institute, Copenhagen, Denmark*

### ABSTRACT

We build a simple model for feedback systems involving small RNA (sRNA) molecules based on the iron metabolism system in the bacterium *E. coli*, and compare it with the corresponding system in *H. pylori* which uses purely transcriptional regulation.

This reveals several unique features of sRNA based regulation that could be exploited by cells.

Firstly, we show that sRNA regulation can maintain a smaller turnover of target mRNAs than transcriptional regulation in iron rich condition without sacrificing the speed of response to sudden iron starvation.

Secondly, we propose that a single sRNA can effectively sort the usage of different target mRNAs.

This suggests that sRNA regulation would be more common in more complex systems which need to prioritize many mRNAs.

#### Reference:

Namiko Mitarai, Anna M. C. Andersson, Sandeep Krishna, Szabolcs Semsey, Kim Sneppen, preprint, q-bio.MN/0611069.

## The cytoskeleton as an example of a highly adaptive structure

Camilla Mohrdieck<sup>1,2</sup>, Florent Dalmas<sup>1,3</sup>

<sup>1</sup>Max Planck Institute for Metals Research, Heisenbergstrasse 3, 70569 Stuttgart

<sup>2</sup>Inst. of Physical Metallurgy, University of Stuttgart, Heisenbergstrasse 3, 70569 Stuttgart/Germany

<sup>3</sup>Present Address: Institut de Chimie et des Matériaux Paris-Est, CNRS - UMR 7182,  
2-8 rue Henri Dunant, 94320 Thiais/ France

### ABSTRACT

The internal polymer network of eukaryotic cells, the cytoskeleton, is a very interesting example of a smart structure that integrates sensors, actuators and control systems to perform many vital cellular functions. It is able to adapt and respond to a large variety of intra and extra-cellular stimuli efficiently and often also interactively. This agility is largely due to a variety of molecules that bind to cytoskeletal fibers to execute certain functions, e.g. crosslinking the fibers. To mimic the adaptiveness of the cytoskeleton in engineered structures, it is necessary to identify the components that act as sensors or actuators and how they interplay.

To address this complex issue, we have focused on the effect of crosslinking on the mechanical stability and the adaptiveness of the cytoskeleton. In a new modeling approach, we describe the cytoskeletal fibers and the molecules that crosslink them into a three dimensional network as homogeneous straight beams in a constant volume. The response to a mechanical stimulus is simulated by subjecting the network to a homogeneous shear stress and calculating its shear modulus. New scaling behaviors of the shear modulus are found and analysed. They indicate general design principles of adaptive networks.

## **Counter Attacking Pandemic H5N1 Bird Influenza by Counter Pandemic.**

John F.Moxnes

*Norwegian Defense Research Establishment, Kjeller, Norway*

### **ABSTRACT**

The Kermack-McKendrick (KM) (1927) epidemiological equations are used to analyze different pandemic scenarios. The infective rate and the withdrawal rate of infected individuals for the Spanish Influenza Pandemic (1918-1920) are found by curve fitting the solution of the KM equations to the historical data for the number of killed and the number of infected individuals during the pandemic. Hypothetically assuming the very same parameters for hypervirulent strains of H5N1 influenza virus (with 50% lethality), our simulations reveal that the latter (without vigorous countermeasures) can infect the total world population during a period of 20-30 days, with a mortality of 50% of the total world population. The short time it takes before the pandemic is over precludes the use of new vaccines that are developed only after a pandemic has started. We examine a logistically more feasible method of achieving rapid immunization after a pandemic has started (and if prefabricated vaccines can not be used either because they are not effective or for logistic reasons): the influence of a counter-pandemic running ahead and immunizing the population before the hypervirulent H5N1 virus attacks. We find that the counter-pandemic can significantly reduce the total death toll during a pandemic with a hypervirulent strain of H5N1 influenza virus. This can be achieved if everything possible is done to hinder geographic dispersal of the hypervirulent virus (e.g. immediate stop of all international passenger traffic, immediate stop of all ordinary road traffic, house quarantine) at the same time as dispersal of the "vaccine virus" is deliberately facilitated by sending it around in a similar way as for a vaccine, but seeding it only in every local population and not in every person as for ordinary vaccine. This might from a logistic point of view be the only feasible method of achieving immunization of a significant proportion of the population in poor countries with poor infrastructure during the very short time interval available before the superpathogen itself normally would be expected to arrive. However, mortality caused by a counterpandemic virus will probably be higher than during an ordinary influenza epidemic, especially among elderly and malnourished persons. Vaccination, using vaccines that have been prefabricated and stored before the start of an eventual pandemic, should therefore be the preferred method of achieving immunization whenever logistically feasible.

## Multigraph approach to social network analysis

Tamas Nepusz

*Research Institute for Particle and  
Nuclear Physics of the Hungarian Academy of Sciences, Dept. of  
Biophysics, H-1121 Budapest, Konkoly-Thege Miklos u. 29-33.*

### ABSTRACT

In life, every individual is connected to other people and every individual is part of a social network. The positions and roles of the individuals, however, vary greatly and an individual simultaneously can be a member of many networks. Based on empirical survey data among members of a defined community with four subdivisions, we constructed four distinct informal networks (informal collaboration, friendship, opinion leadership and social capital networks), and compared to a formal co-operation network of the same community. Subgroups within the community were detected by the strength of relationships between people. The number of subgroups varied in the different networks but characteristically formed within the formal subdivisions. Result shows that informal professional and personal relationships form denser networks than social capital or opinion leadership do suggesting that we utilize people weakly connected to us to obtain information and resources important to us. Results also offer empirical evidence for the similarity between opinion leaders and social capital brokers. Having able to construct four different informal networks that relate to each other in varying degree suggest that treating informal networks in organizational studies and organizational sociology is likely to be misleading.

## **igraph - a new software package for complex network research**

Tamas Nepusz and Gabor Csardi

*Research Institute for Particle and  
Nuclear Physics of the Hungarian Academy of Sciences, Dept. of  
Biophysics, H-1121 Budapest, Konkoly-Thege Miklos u. 29-33.*

### **ABSTRACT**

igraph is a new, open source portable software library specifically aimed at the analysis of large graphs with millions of vertices. It contains routines for creating, manipulating and visualizing complex networks, calculating various structural properties, cliques, clusters, independent vertex sets. It is also capable of importing from and exporting to various file formats (GraphML and Pajek for instance). It has been tested and used on various platforms, including (but not limited to) Windows, Mac OS X, Sun Solaris and various flavors of Linux. igraph was originally written in 100% C, and it is usually faster than most other graph analysis packages. It currently contains interfaces to the R statistical programming environment and to the Python programming language, enabling researchers to test new ideas and implement algorithm prototypes quickly, without the need to interact with lower-level C functions. For instance, the basic implementation of the well known Google PageRank algorithm is only 12 lines using the Python interface of igraph. Interfaces to other high level languages (such as Perl, Ruby or Java) can easily be added by third party developers.

## Optimal Synthesis of heat supply systems with renewable energy sources

V. Nikulshin<sup>1</sup>, V. von Zedtwitz<sup>2</sup>

<sup>1</sup>Professor and Head of Department, Odessa National Polytechnic Univ., Ukraine,  
e-mail: vnikul@paco.odessa.ua

<sup>2</sup>PhD student, ETH, Zurich, Switzerland

### ABSTRACT

The processes taking place in complex energy intensive systems with renewable energy sources are characterized by mutual transformation of quantitatively different power resources. For this reason the thermodynamic analysis and optimization of such systems is based on combined application of both laws of thermodynamics and demands the exergy approach [1]. Exergetic methods are universal and make it possible to estimate the fluxes and balances of all energy for every element of the system using a common criterion of efficiency. Therefore, the exergetic methods are meaningful in analysis and calculations.

Despite its usefulness, the benefits of the exergetic approach were not fully realized until recent years. One reason for this situation is its underestimation of exergetic functions for mathematical modeling, syntheses, and optimization of flow sheets. Another reason is its mathematical difficulty in thermodynamic analyses.

Fig. 1. Solar-heat pump systems with season heat storage.

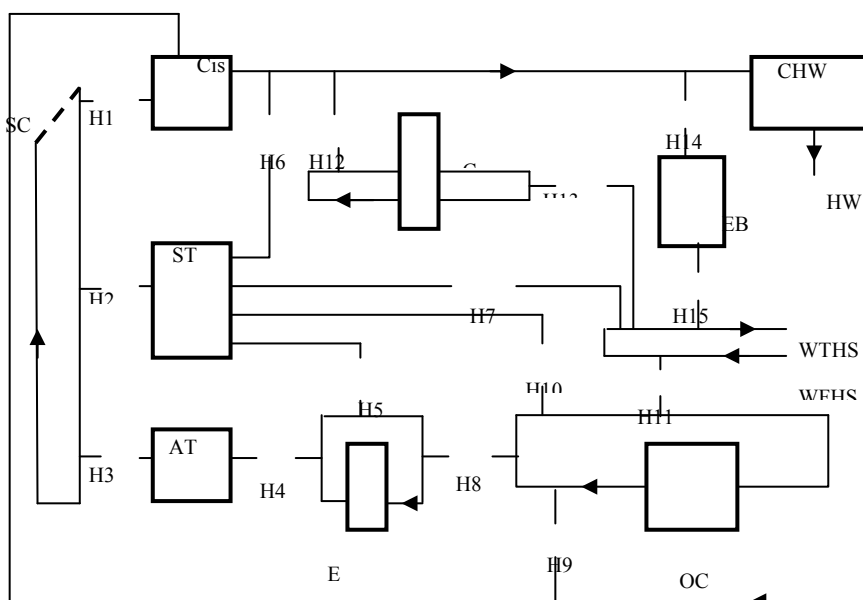

Flows: CW - cold water; HW- hot water; WTHS - water to heating system; WFHS- water from heating system. Elements: H1-H15 - heat exchangers; SC- solar collector; Cis - cistern; ST - season storage tank; AT - antifreeze tank; E- evaporator of heat pump; C - condenser of heat pump; OC - oil cooler of heat pump; EB - electric boiler; CHW - cistern of hot water.

Meanwhile, the increasing complexity of optimization problems requires more effective and powerful mathematical methods. Hence, during the last few years, many papers with different applications of exergetic methods have been published (see for example [2-4]).

The above referenced papers as well as the authors past investigations (see [5,6,8,9,10,11]) show that one of the most effective mathematical methods used for exergetic analysis and optimization is the method of graph theory [7]. The usefulness of graph models can also be demonstrated by its flexibility and its wide varieties of possible applications.



Possible exergy topological methods include the sole use or combination of exergy flow graphs, exergy loss graphs, and thermoeconomical graphs [5,6,8,9,10,11].

This paper describes the general approach for thermoeconomical optimization of energy intensive systems with linear structure. Suggested method is based on building and analysis of special graph of thermoeconomical expenditure.

The suggested approach was applied for the optimization of a solar- heat pump systems with season heat storage (SHPS) with the total heat productivity of 0.5 MW (see Fig. 1.).

The main difference of a SHPS from others energy intensive systems with traditional energy sources is the presence of a "charge-free" source -the sun.

However, the use of the thermoeconomics approach allows to take into account real exergy losses in the subsystem: a solar collector - the heat exchangers and to find the certain cost of the SHPS as a whole.

It is shown that the application of the suggested method allows to receive the minimum value of thermoeconomical expenditures of a system  $Z_{\Sigma}^{opt} = Z_{1-1-3-2} = 2502$  USD/year.

The optimal variant for the SHPS with total heat production of 0.5 MW is the system with a Solar Collector  $A_{SK} = 1000 \text{ m}^2$ , Season Storage Tank  $V_{ST} = 3000 \text{ m}^3$ , use factor for Heat Pump  $n = 0.6$ , use factor for Electric Boiler Heat  $s = 0.4$ .

## REFERENCES

1. Bejan, A., Tsatsaronis, G., Moran, M. (1996) *Thermal Design and Optimization*, John Wiley & Sons Inc., New York..
2. Erlach B., Tsatsaronis G., Czesla F. (2001) A new approach for assigning cost and fuels to cogeneration products, *Proc. of International Conference ECOS-01*, Istanbul, Turkey, pp.107-115.
3. Casarosa C., Franco A.(2001) Thermodynamic optimization of the operative parameters for the heat recovery in combined power plants, *Int. Journal of Applied Thermodynamics* Vol.4, N1, pp.43-52.
4. Cornelissen, R.L., van Nimwegen, P.A., Hirs, G.G. (2000) Exergetic life cycle analysis", *Proc. of International Conference ECOS-2000*, Twente, Netherlands, pp.1131-1143.
5. Nikulshin, V., Wu, C. (2000) Thermodynamic analysis of energy intensive systems on exergy topological models, *Proc. of 12-Th. International Symposium on transport phenomena*, ISTP-12, Istanbul, Turkey, pp. 341-349.
6. Nukulshin V., Wu C., Nikulshina V. (2001) Exergy efficiency calculation of energy intensive systems by graphs", *Proc. of International Conference ECOS-01*, Istanbul, Turkey, pp.107-115.
7. Harary F. (1995) *Graph Theory*. Narosa Publishing House, New Deli.
8. Nikulshin, V., Wu, C. (1999) Method of thermodynamic analysis and optimization of energy intensive systems on exergy flow graphs, *Proc. of International Conference on Power and Energy Systems*, Las Vegas, Nevada, USA, pp.489-491.
9. Nikulshin V., Wu C., Bailey M., Nikulshina V.(2002) Method of thermoeconomical optimization on graphs of energy intensive systems with pair interplay of flows, *Proc. of International Conference ECOS-02*, Berlin, Germany, pp.1477-1484.
10. Nikulshin V., Zedtwitz V., Thermodynamic analysis of air refrigerator on exergy graph, *Thermal Science*, Vol.10, No1, pp. 99-110, 2006.

## Laser like super weak light emission of plant cell during its life cycle

Paiziev A. ,Krakhmalev V,

*Institute of Electronics Uzbek Academy of Sciences, Tashkent*

### ABSTRACT

The phenomenon of super weak luminescence of plants and animal is established and is affirmed by many investigators. However we have not found out of literature data about research of superweak luminescence of separate plant or animal cell and even more so visualization of separate single plant cell luminescence. Developing cotton fibers on seed surface of cotton plant is extremely convenient object for that visualization.

The present work has been performed on living hairs of cotton seed-bud for sorts *Tashkent - 1*, *C-4727*, *Gossipium hirsutum*, *Turfan guza G.herbaceum*, *C-6063 G. barbadense L.* and wild form *G. raimondii L.* For registration of superluminescence from apical part of cotton hair, in first the original method of replica imprints was used. Replica imprints were obtained by spraying aqueous solutions (for example, gelatine), which tightly coat the surface of living cotton hairs. have used polymers of the different nature: a polyvinylpyrrolidone, gelatin, polymethyl methacrylate etc. The hardened polymer had been separated from seed-bud and together with entrapped cotton hairs investigated under optical microscope “Neophot-2”.

Emitting of a radiation flux is detected via observation of peculiar figures under optical microscope in a thickness of polymer films. For investigated cotton sorts a glow figure (more exact -the radiation tracks) watched in apical parts of cotton hairs (see Fig.1). In regard to mechanism formation of peculiar figures in polymer substance around apical parts of cotton hairs we can not tell strong something yet. It is possible only to suggest, that the observed phenomenon is not caused by a photo effect, as the utilized polymers are not photographic emulsions. In second, in liquid (solutions of polymers) can not leave visible tracks neither light quantum (such as a laser radiation), nor components of a protoplast separating by cell-hairs in an environment. Under operating of high energy radiation the active chemical radicals are formed. As a result of osmotic detonating components of a protoplast (N, P, K, phenol, it derives and other matters, erectable by cell) neutralize the radicals. In result visible under microscope luminous figures is formed. Such according to our thinking, is mechanism formation of pictures, visible under a microscope and creating illusion of constant glow of an apex.

We shall mark also, that for cotton hairs of all forms and sorts there is one feature – emitting focusing irradiation have cone like form. That the radiation of cotton hair really has the electromagnetic nature, we were convinced by experience with usage of the photoelectric multiplexer (PEM) such as 6256 made by corporations EMI and sensing to a ultraviolet radiation.

### References

Krakhmalev, V., Paiziev, A.,. (2005). The visualization of natural luminescence of living cotton hairs. *Luminescence*, 20: 451–454

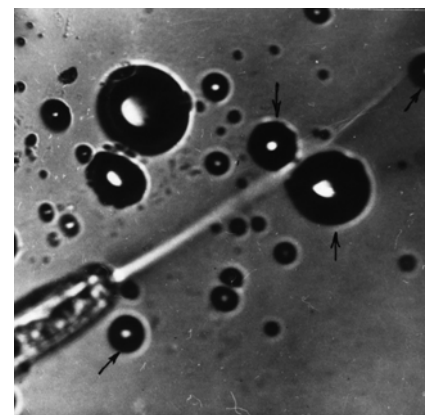

**Figure 1**

## COLOR VISUALIZATION OF TISSUE CELLS.

Paiziev A., Krakhmalev V.,

*Institute of Electronics, Uzbek Academy of Science, Tashkent email: adxam\_paiziev@rambler.ru*

### ABSTRACT

**Introduction:** Color visualization are widely spread in biological and medical studies of difference samples. But for this purpose need special treatment of samples under expensive chemical prepares. This procedure is changing native structure biomedical sample and lead to distorted its image under microscope. Other method for color visualization is connected with using interference microscope based on transmission of white light through bio-medical sample. But this microscope have complicated additional and expensive optical system for getting two coherent light.

**Materials & Methods:** To get most cheep and convenient method color visualization human tissue cells, (blood cells, urine, saliva and other physiological liquids) without any chemical treatment and using expensive interference microscope we proposed new method based on using ordinary optical microscope and special substrate on what we put the investigating sample. Measurements has been performed for human tissue, blood cells, saliva and urine for health perfect and for difference stage cancer patients. Method based on light interference reflected from sample surface and supporter.

**Results:** Developed new technique for fast in real time regime to get color image of human blood cells without any chemical treatment. This method let us to determine chemical compounds of blood cells by comparison this color image with calibrate color map. In Figure 1 and 2 showed example of color image of human blood cells by new method and black and whit image by ordinary method what used in medical practice.

**Discussion and conclusion:** We offer new method to get two coherent light based on biomedical sample reflection and special no transparence supporter reflection of the white light. In result we can see color interference picture (Fig.1.) of the biomedical sample under ordinary optical microscope without using any chemical treatment and expensive interference microscope. This method may be used in medical laboratory, hospitals, research centers and individual users for fast public and self diagnostics.

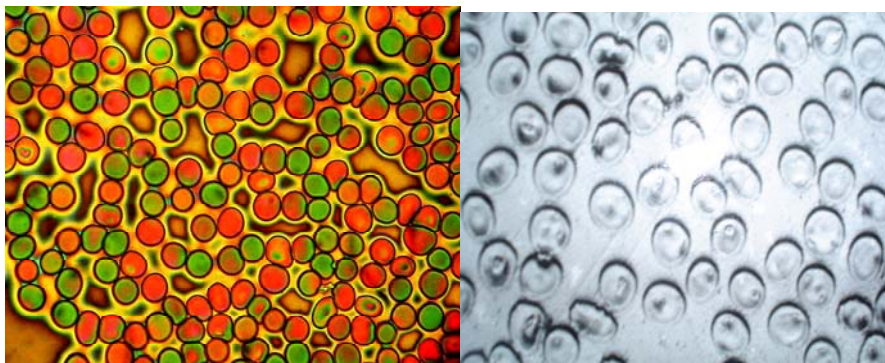

**Fig. 1**

**Fig. 2**

## The Climate Model for the Atmosphere-Ocean System based on Complex Neural Network Architecture Design

Oleg M. Pokrovsky

*Main Geophysical Observatory, St. Petersburg, 194021, Russia,*

### ABSTRACT

A multivariate self-learning fuzzy-neural model has been developed to describe predictive relationships between evolving large-scale patterns in North Atlantic: sea surface temperature (SST), atmospheric pressure and temperature (predictors) and subsequent patterns in the Europe air surface temperature and precipitation (predictands). A lead interval of varying length (from 1 to 6 months) is placed between a series of consecutive predictor periods and a single predictand period. Objective evaluation of strength of such relationships is a primary aim of this study. Statistical analyses provide an empirical knowledge that can lead to more skillful forecasts in the absence of explicit physical understanding. Additionally, acquired information may provide guidance towards identification of the physical process, contributing to or limiting the predictability. The choice to use an empirical approach reflect the fact that both simple and complex general circulation models (GCMs), either with prescribed boundary conditions or with actual oceanic coupling, currently do not adequately reproduce the processes of the real atmosphere at the lead times an averaging periods of concern here. We hope and assume that eventually, with advances in physical understanding, dynamic prediction approaches will outperform statistical ones. Prediction of time-averaged surface climate has received a considerable attention over last two decades. Neural network (NN) is a powerful nonlinear scheme based on “black box” statistics, where one can tune the model parameters to arrive at a good prediction, but can see neither the phase relation between the predicand and predictors, nor the origin of skills. Therefore, we assume that the predictability of seasonal climate is connected with forcing fields such as the SST or others. The key to a truly successful application of NN model lies in the understanding of the underlying physical mechanism for the relation between predictor and predictand fields (Pokrovsky, 2000). The decision to use the principal fuzzy patterns (PFPs) of the surface atmospheric pressure and temperature as predictor fields is based on findings of other studies on the field teleconnections (Namias, 1982; Lanzante, 1984). Comparison of EOFs (empirical orthogonal function) and PFPs computed for surface atmospheric pressure and air temperature fields has been carried out and its results are analyzed. PFP advantages for field anomaly performance is demonstrated (Pokrovsky et al, 2002). Following teleconnection spatial areas (Barnston and Livezey, 1987) were selected to derive PFPs for Europe model: North-Atlantic Oscillation (NAO), East Atlantic (EA), EA Jet (EAJ), East-Atlantic/West Russia (EAWR), Scandinavia (S), Polar/Eurasian (PE). In this respect implementation of optimal design technique (Pokrovsky and Roujean, 2003) permits to determine an optimal set of predictors (PFPs) representing key low-oscillation patterns, which are most informative with respect to the predictand field for a prescribed lead interval. Five layers neural network utilizes fuzzy classification input and out layers and radial basis functions (RBF) for PFPs as the activated units. Whole atmosphere-ocean model is composed by a set of branches including above structured neural networks. Our study demonstrated that the complex model architecture design impacts greatly on prediction reliability and efficiency. Important result is that the inter-modules linkages described some natural feedbacks in climate system should be identified and evaluated at a long time series. Monthly time series (reanalysis NCEP) for 1948-1998 was split in two parts: the learning and

verification samples. In contrast to the GCMs our self-learning model accumulates all past observing data in so way that after 35 years of learning process it could provide very competitive prediction results for air surface temperature fields. It captured both positive and negative phases of above climate indexes as well as transition periods in their relationships with predicands fields. It is demonstrated a series of monthly observed and forecasted grid temperature fields over Europe for last decade of twentieth century. Forecasted fields reproduce main features of analysis grids. Deviation and other proper statistics are discussed. In particularly, achieved level for explained variance of predicted fields is much higher than those accessible for linear regression (see Blender et al, 2003). Partition of Europe at the set of the homogeneous climate ranges by fuzzy regioning is discussed. Forecasted and observed temperature and precipitation time series for several climate areas are considered. Skillful magnitudes are analyzed as well. Recommendations for further studies are formulated.

*References:*

- Barnston. A., Livezey G., 1987. Classification, seasonality and persistence of low-frequency atmospheric circulation patterns, *Mon. Weather Rev.*, v.115 p. 1083-1126.
- Blender R., Luksch U., Fraedrich K. and C.Raible., 2003, Predictability study of the observed and simulated European climate using linear regression, *Q. J. R. Met. Soc.*, v.129, p.2299-2313.
- Lanzante J.R. 1984, A rotated eigenvalue analysis of correlation between 700 mb heights and sea-surface temperature in the Pacific and Atlantic, *Mon. Weather Rev.*, v.112, p. 2270-2280.
- Namias J., 1982, Teleconnections of 700 mb height anomalies for the Northern Hemisphere, *Mon. Weather Rev.*, v.110, p. 824-828.
- Pokrovsky O.M., 2000. Land Surface Energy Exchange Simulation Based on Combined "Fuzzy Sets and Neural Networks" Approach. *Proceedings of Second Conference on Artificial Intelligence*, AMS, Boston, MA, p.21-26.
- Pokrovsky O.M., Roger H.F. Kwok and C.N. Ng , 2002. Fuzzy logic approach for description of meteorological impacts on urban air pollution species: a Hong Kong case study.- *Computers and Geosciences*, v. 28, N 1, 2002, p. 119-127.
- Pokrovsky, O.M., and J.L. Roujean, 2003, Land surface albedo retrieval via kernel-based BRDF modeling: II. An optimal design scheme for the angular sampling, *Remote Sens. Environ.*, 84, 120-142.

## **Predicting power law distributed avalanches: implications for earthquake forecast**

Osvanny Ramos

*Physics department, University of Oslo, Norway*

### **ABSTRACT**

It is a very common belief that power law distributed avalanches are inherently unpredictable. It mostly comes from the concept of "Self-organized criticality", where criticality is often interpreted in the way that at any moment, any small avalanche can eventually cascade into a large event; with the supposed implication of unpredictability of earthquakes, the most catastrophic example of those ideas. Nevertheless, this work demonstrates the possibility of avalanche prediction in both experiments and simulations where the distributions of avalanches follow a power law. By knowing the position of every grain in a sandpile experiment, avalanches of moving grains follow a distinct power law distribution. Large avalanches are preceded by continuous, detectable variations in the internal structure of the pile. Finally, the possibility of avalanche prediction, through monitoring variations in the structure of the system, is generalized by using a classical earthquake model.

## **Tracking changes in gene expression through the generations by single cell encapsulation**

AC Rowat, JJ Agresti, DA Weitz

*Dept. of Physics/DEAS, Harvard University, 40 Oxford Street, Cambridge, Mass, 02138 USA*

### **ABSTRACT**

Within a population of genetically identical cells, levels of gene expression vary; such variation may benefit the adaptation of a population of cells exposed to changing environmental conditions. To gain insights into the mechanisms that regulate heterogeneity in gene expression under environmental stress, we are developing tools to study variations in gene expression of single cells and their progeny in different environmental conditions. We encapsulate cells in polydimethylsiloxane (PDMS) devices: single cells are placed in long chambers wide enough for only one cell. The cells are thus constrained to grow in a line, making it easy to study several generations of cells originating from the single, encapsulated cell, and monitor levels of GFP-tagged proteins in the cells and their progeny by fluorescence microscopy. These studies provide insights into heritable patterns of gene expression, and ultimately, into the role of epigenetic mechanisms in adaptation and evolution.

## **Acoustic Emission Measurements to Simulate Triggering Effect of weak Physical Fields**

Natalia Zhukova

*Dynamics of Geophysical Fields and Computation Mathematics, Tbilisi, Georgia*

### **ABSTRACT**

Numerous examples of effect of seismicity triggering by natural or man-caused vibrations may be considered as a demonstration that some technological actions to seismic generating structures in order to prevent strong earthquake are accessible. The idea of nonexplosive vibroseismic triggering of weak seismicity to quicken the relaxation of tectonic overstresses and therefore to reduce the hazard of catastrophic earthquake become more and more attractive. It is well known that Acoustic Emission (AE) is a good indicator of inelastic straining processes and microfracture of terrestrial material. It was used in our experiments with marble and granitic specimens under creep test in presence of weak vibrations. The results of this work may demonstrate the examples of vibration triggered growth of straining rate and AE activity of loaded solids. Experimental set up of our experiments represents a system of two plates of roughly finished basalt (with average height of surface asperities of 0.1-0.2 mm), where a constant pulling force was applied to the upper (sliding) plate. In addition, the same plate was subjected to electric periodic (50 Hz) perturbations with variable amplitude, which was much weaker when compared to the pulling.



## 4 Participants

### Organising Committee

**Name**

Skjeltnop, Arne T.  
Director

**Address**

Institute for Energy Technology  
POB 40  
NO-2027 Kjeller  
Norway  
[arne.skjeltnop@ife.no](mailto:arne.skjeltnop@ife.no)

Belushkin, Alexander V.  
Co-director



Frank Laboratory of Neutron Physics  
Joint Institute for Nuclear Research  
141980 Dubna, Moscow region  
Russia  
[belushk@nf.jinr.ru](mailto:belushk@nf.jinr.ru)

Løkseth, Trine  
Secretary



Institute for Energy Technology  
POB 40  
NO-2027 Kjeller  
Norway  
[trine.loekseth@ife.no](mailto:trine.loekseth@ife.no)

Helgesen, Geir  
Technical assistant



Institute for Energy Technology  
POB 40  
NO-2027 Kjeller  
Norway  
[geir.helgesen@ife.no](mailto:geir.helgesen@ife.no)

**Programme Committee/Lecturers**

**Name**

Agol, Vadim



**Address**

Institute of Poliomyelitis and Viral  
Encephalitides, Moscow,  
Russia  
[agol@belozersky.msu.ru](mailto:agol@belozersky.msu.ru)

Berg, Johannes



Institute for Theoretical Physics,  
University of Cologne,  
Germany  
[berg@thp.uni-koeln.de](mailto:berg@thp.uni-koeln.de)

Breivik, Jarle



Institute for Basic Medical Science,  
University of Oslo,  
Norway  
[jbreivik@medisin.uio.no](mailto:jbreivik@medisin.uio.no)

Giaever, Ivar T.

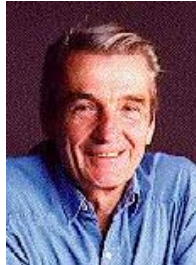

Physics Department  
Rensselaer Polytechnic Institute  
Troy, NY 12180-3590  
USA  
[giaevi@rpi.edu](mailto:giaevi@rpi.edu)

Hauert, Christoph



Program for Evolutionary Dynamics  
Harvard University,  
One Brattle Square  
Cambridge, MA  
USA  
[Christoph\\_hauert@harvard.edu](mailto:Christoph_hauert@harvard.edu)

Jensen, Mogens Hoegh



Niels Bohr Institute  
Blegdamsvej 17  
DK-2100 Copenhagen  
Denmark  
[mhjensen@nbi.dk](mailto:mhjensen@nbi.dk)

Kloster, Morten



33

University of California,  
San Francisco,  
USA  
[kloster@pharmacy.cusf.edu](mailto:kloster@pharmacy.cusf.edu)

Lenski, Richard E



Michigan State University,  
East Lansing MI 48824  
USA  
[lenski@msu.edu](mailto:lenski@msu.edu)

Lia, Brynjar



Norwegian Defence Research  
Establishment,  
2027 Kjeller,  
Norway  
[Brynjar.lia@ffi.no](mailto:Brynjar.lia@ffi.no)

McCauley, Joe



Physics Dept.  
Univ. of Houston, Houston  
TX 77204  
USA  
[jmccauley@uh.edu](mailto:jmccauley@uh.edu)

Krishna, Sandeep



Niels Bohr Institute  
Blegdamsvej 17  
DK-2100 Copenhagen O  
Denmark  
[sandeep@nbi.dk](mailto:sandeep@nbi.dk)

Ostrovsky, Mikhail



Institute of Bio-Chemical Physics  
Russian Academy of Sciences  
Kosygin St 4  
117334 Moscow  
Russia  
[Ostrovsky3535@mail.ru](mailto:Ostrovsky3535@mail.ru)

Paulsson, Johan Martin



34

Department of Systems Biology  
Harvard Medical School  
200 Longwood Avenue  
Boston, MA 02115  
[johan\\_paulsson@hms.harvard.edu](mailto:johan_paulsson@hms.harvard.edu)

Pynn, Roger



Indiana University Cyclotron Facility  
2401 Milo B. Sampson Ln  
Bloomington, IN 47408-1398  
[pynn@mrl.ucsb.edu](mailto:pynn@mrl.ucsb.edu)

Sherrington, David



Theoretical Physics  
University of Oxford  
1 Keble Road  
Oxford, OX1 3NP  
England  
[d.sherrington1@physics.ox.ac.uk](mailto:d.sherrington1@physics.ox.ac.uk)

Skulachev, Vladimir



Belozersky Institute of Physico-  
Chemical Biology, Moscow State  
University,  
Russia  
[skulach@belozersky.msu.ru](mailto:skulach@belozersky.msu.ru)

Stavans, Joel



Department of Physics of Complex  
Systems  
Weizmann Institute of Science  
PO Box 26  
Rehovot 76100  
Israel  
[festava@wisemail.weizmann.ac.il](mailto:festava@wisemail.weizmann.ac.il)

Svenningsen, Sine Lo



Bassler Lab,  
Dept. of Molecular Biology  
Princeton University,  
USA  
[ssvenmin@princeton](mailto:ssvenmin@princeton)



Niels Bohr Institute  
 Blegdamsvej 17  
 DK-2100 Copenhagen Ø  
 Denmark  
[sneppen@nbi.dk](mailto:sneppen@nbi.dk)



Dept. of Physics  
 University of Basel  
 CH-4056 Basel  
 Switzerland  
[Harry.Thomas@unibas.ch](mailto:Harry.Thomas@unibas.ch)



Niels Bohr Institute  
 Blegdamsvej 17  
 DK-2100 Copenhagen  
 Denmark  
[trusina@nbi.dk](mailto:trusina@nbi.dk)

**Participants**

<b>Name</b>	<b>Address</b>	<b>e-mail</b>
Agresti, Jeremy Jon	Engineering Sciences Laboratory 40 Oxford St. Cambridge, MA 02138	ja@deas.harvard.edu
Ahlsing, peter Toke Heden	Niels Bohr Institute, Blegdamsvej 17, 2100 Copenhagen, Denmark	ahlgren@nbi.dk
Akbas, Etem	Mersin University – Faculty of Medicine Dept. Medical Biology and Genetics Yenisehir Campus7 MERSIN	etem_a@yahoo.com
Anisimova, Larysa	Management Problems and Ecology, National Academy of Sciences of Ukraine, Dnepropetrovsk, 49000, Ukraine	Lanisimova@gmail.com
Antunes, Andrei	CFTC (Centro Fisica Teoria e Computacional) Av. Joao XXI,57, 5 ESQ	asma@cii.fc.ul.pt
Arikan, Mehmet Salyh	Suleyman demýrel Ünyversýtesý Tip Fakültesý Hastanesý Mýkrobýyolojý Laboratuari Isparta Turkey	Msa_76@hotmail.com
Avlund, Mikkel	Niels Bohr Institute, Blegdamsvej 17, 2100 Copenhagen, Denmark	avlind@nbi.dk
Babich, Polina	Saint-Petersburg State Polytechnical University Kollontay str. 33 block 1, apt.62 Saint-Petersburg Russia 193312	ptahap@yandex.ru
Bergli, Joakim	Fysisk Institutt Postboks 1048 Blindern 0316 Oslo Norway	jbergli@fys.uio.no

Borossiva, Daniela	Acad. G Bonchev St., blick 2 Sofia – 1113 Bulgaria	<a href="mailto:dborissova@iit.bas.bg">dborissova@iit.bas.bg</a>
Brutovsky, Branislav	Institute of Physics P.J.Safarik University jesenna 5 04154 Kosice Slovakia	<a href="mailto:bru@seneca.Science.upjs.sk">bru@seneca.Science.upjs.sk</a>
Carpenter, Holly	Emory University 105 Sycamore Pl. Apt. 603A Deatur, GA 30030 USA	<a href="mailto:hecarpe@learnlink.emory.edu">hecarpe@learnlink.emory.edu</a>
Cernak, Jozef	Department of Biophysics University of P. J. Safarik Jesenna 5 SK-04000 Kosice Slovak Republic	<a href="mailto:jcernak@kosice.upjs.sk">jcernak@kosice.upjs.sk</a>
Christophorov, Leonid	Bogoliubov Institute for Theoretical Physics, NAS Ukraine 14B Metrologichna Str. Kiev 03143, Ukraine	<a href="mailto:lchrist@bitp.kiev.ua">lchrist@bitp.kiev.ua</a>
Dubrovin, Evgeniy	Vorobyovy gory, ½ Faculty of Physics, Moscow State University, Moscow, 119991, Russia	<a href="mailto:dubrovin@polly.phys.msu.ru">dubrovin@polly.phys.msu.ru</a>
Fossum, Jon Otto	Norwegian University of Science and Technology (NTNU), 7491 Trondheim, Norway	<a href="mailto:Jon.fossum@phys.ntnu.no">Jon.fossum@phys.ntnu.no</a>
Goksu, A. Yasemin	Istiklal Mah.fatih SOK. 21/5 32300 ISPARTA Turkey	<a href="mailto:Yasemin.goksu@gmail.com">Yasemin.goksu@gmail.com</a>
Hakobyan, Nune	Facultu of Biology, Yerevan state University, Alex Manoogyan str. 1, 0025, Yerevan, Republic of Armenia	<a href="mailto:nunehokobyan@rambler.ru">nunehokobyan@rambler.ru</a>

Heiberg-Andersen, Henning	Institute for Energy Technology POB 40 NO-2027 Kjeller, Norway	<a href="mailto:henning.heiberg-andersen@ife.no">henning.heiberg-andersen@ife.no</a>
Horvath, Denis	Dept. of Theoretical Physics and Astrophysics, University of P. J. Safarik Partk Angelinum 9, Kosice Slovak Republic	Horvath.denis@gmail.com
Jauffred, Liselotte	Niels Bohr Institute, Blegdamsvej 17, 2100 Copenhagen, Denmark	jauffred@nbi.dk
Karol, Andrei	Research center of spectrometry an neurography Leningradskaya 10/16 141980 Dubna, Moscow region Russia	Karol@jinr.ru
Knudsen, Kenneth D.	Institute for Energy Technology POB 40 NO-2027 Kjeller Norway	<a href="mailto:kenneth.knudsen@ife.no">kenneth.knudsen@ife.no</a>
Kruchkova, Olga	Bryansk open Institute of management and business Ul.Orlovskaya 27, kv. 272, 241012 Bryansk Russia	Olga_bbi@rambler.ru
Liu, Ying	Niels Bohr Institute, Blegdamsvej 17, 2100 Copenhagen, Denmark	yingliu@ruc@yahoo.com.cn
Maftuleac, Daniela	Faculty of Mathematics, Moldova State University str. Gr. Alexandrescu, 17/1 Ap. 64, MD-2008 Chisinau, republic of Moldova	maftuleac@yahoo.com
Meakin, Paul	Center for Advanced Modeling and simulation (CAMS) Idaho National Laboratory USA	Paul.meakin@inl.gov
Medvedeva, Anna	1/12 Leninskie Gory Dept. of Development of Biology	Repa-pa@yandex.ru



	119992 Moscow Russia	
Mengel, Anne Benedicte	Copenhagen University Denmark	m_benedicte@hotmail.com
Micheelsen, Mille	Niels Bohr Institute, Blegdamsvej 17, 2100 Copenhagen, Denmark	millemi@m2.stud.ku.dk
Milibaeva, Guljamal	Uzbek Academy of Sciences, Heat Physics Department, Laboratory of perspective studies 700135 28 Katartal Str., Tashkent Uzbekistan	sabmax1@mail.ru
Mitarai, Namiko	Niels Bohr Institute, Blegdamsvej 17, 2100 Copenhagen, Denmark	mitarai@nbi.dk
Mohammed, Amjed	Oldenburg University Schützenweg 22 26129 Oldenburg Germany	amjed@mail.uni-oldenburg.de
Mohrdieck, Camilla	Max-Planck Institute for Metals research, Heissenbergstrasse 3. Germany	mohrdieck@mf.mpg.de
Moxnes, John F	Norwegian Defence Research Establishment Kjeller, Po. Box 25, NO-2007	john-f.moxnes@ffi.no
Muller, Jiri	Institute for Energy Technology POB 40 NO-2027 Kjeller Norway	jiri.muller@ife.no
Måløy, Knut Jørgen	Fysiks Institutt Postboks 1048 Blindern 0316 Oslo Norway	k.j.maloy@fys.uio.no
Nepusz, Tamás	Dep. Of Biophysics Research Institute for Partickle and Nuclear Physics Konkoly-Thege Miklos u. 29-33	ntamas@rmki.kfki.hu

	1121 Budapest Hungary	
Neslihan, Turk	Istanbul Univeristy, Cerrahpasa Faculty of Medicine Dep. of Medical Biology, 34098, Cerrahpasa Istanbul, Turkey	Nes_trk@ogr.iu.edu.tr
Nikulshin, Vladimir	Ave. Shevchenko, 1, Odessa National polytechnic University Odessa, 27044 Ukraine	vnikul@paco.odessa.ua
Olshevskiy, Alexander	Bryansk State Technical University Bulvar 50-letiya Oktyabrya, 7, Bryansk, Russia, 241035	dsmssoft@rambler.ru
Ostapchuk, Yuriy	Faculty of Physics, Kyiv National Taras Shevchenko University, Prosp. Glushkova, 2, build. 1 Ukraine	os@ukr.net
Paiziev, Adkhamjon	Institute of electronics Uzbek Acad. Sci F.Khodjaeva str. 33 Academgorodok Tashkent 700125, Uzbekistan	Adxam_payziev@rambler.ru
Pogrovsky, Oleg	Main Geopgysical Observatory Karbyshev str. 7 St. Petersburg, 194021 Russia	pokrov@main.mgo.rssi.ru
Ramos, Osvanny	Dep. of Physics P.O.Box 1048 Blindern N-0316 Oslo	osvanny@fys.uio.no
Rowat., Amy	Engineering & Sciences Laboratory 40 Oxford Street Cambridge, MA 02138 USA	rowat@deas.harvard.edu
Sadoyan, Avetis Abel	Dep. of Physics Yerevan state University	asadoyan@ysu.am

	Alex Manoogian 1 375025 Yerevan Armenia	
Salomov, Uktam	Heat Physics Department of Uzbek Academy of Sciences 700135 28 Katartal Str., Tashkent Uzbekistan	salukrah@yahoo.com
Santucci, Stephane	Dep. of Physics P.O.Box 1048 Blindern N-0316 Oslo	Stephane.santucci@fys.uio.no
Shantsev, Daniel	Dep. of Physics P.O.Box 1048 Blindern N-0316 Oslo	dansh@fys.uio.no
Smitienko, Olga	117997, Moscow, Kosygin str. 4 NM Emanuel Institute of Biochemical Physics of the Russian Academy of Sciences	<a href="mailto:djolia@mail.ru">djolia@mail.ru</a>
Uhomoibhi, James	Faculty of Engineering University of Ulster Shore Road, Newtownabbey BT37 0QB Northern Ireland, UK	j.uhomoibhi@ulster.ac.uk
Vitalie, Eremeev	Institute of Applied Physics Academy of Sciences of Moldova Academiei str. 5, Chisinau MD-2028 Republic of Moldova	Vitalie.ermeev@gmail.com
Werner, Maria	Niels Bohr Institute, Blegdamsvej 17, 2100 Copenhagen, Denmark	Mariawer@kth.se
Yazykov, Vladislav	Bryansk State Technical University bul. 50-letiya Oktyabrya, 7 241035, Bryansk Russia,	well@tu-bryansk.ru
Zhukova, Natalia	Dynamics of Geophysical Fields and Computational Mathematics M.Nodia Institute of geophysics, 1, Alexidze Str. 0193 Tbilisi Georgia	Natalia27ccp@gmail.com





Institute for Energy Technology

Institute for Energy Technology

P.O. Box 40

NO-2027 Kjeller

Norway

Tlf 0047 63 80 60 00

Telefax 0047 63 81 63 56

[www.ife.no](http://www.ife.no)