

Manuscript Details

Manuscript number	SAFETY_2017_976
Title	Visualizing risk related information for work orders through the planning process of maintenance activities
Article type	Research Paper

Abstract

Major accidents are characterized by complex causal patterns with many factors influencing the occurrence of such accidents. Within the offshore petroleum industry the causes can be found not just in the execution of maintenance work, but also in the preparations and planning before performing the work. Planning of the work activities plays an important role in managing the activities and installation risk by identifying hazards and ensuring measures are planned for. One important basis for developing good plans and plan the work properly is to have the right information available at the right time in a format that facilitates understanding of important risk related aspects of the work. This paper presents a computerized display for a concept for how risk related information can be visualized in an operational context when establishing work orders. Design iterations have included participants from operating companies on the Norwegian continental shelf.

Keywords	Visualizing risk; risk understanding; planning process; work order; maintenance activities
-----------------	--

Taxonomy	Risk Management, Decision Making Tool, Oil Industry, Safety in the Workplace, Hazard Analysis, Information Visualization
-----------------	--

Manuscript region of origin	Europe
------------------------------------	--------

Corresponding Author	Sizarta Sarshar
-----------------------------	-----------------

Corresponding Author's Institution	Institute for energy technology
---	---------------------------------

Order of Authors	Sizarta Sarshar, Stein Haugen
-------------------------	-------------------------------

Submission Files Included in this PDF

File Name [File Type]

CoverLetter.docx [Cover Letter]

Abstract.docx [Abstract]

TitlePage.docx [Title Page (with Author Details)]

Manyscript.docx [Manuscript (without Author Details)]

To view all the submission files, including those not included in the PDF, click on the manuscript title on your EVISE Homepage, then click 'Download zip file'.

Cover letter

Dear Editor,

We are submitting a manuscript for consideration of publication in Journal of Safety Science. The manuscript is entitled "Visualizing risk related information for work orders through the planning process of maintenance activities".

We have tried to anonymize the paper as best could, but we believe reviewers might identify the authors since the paper builds on previous published journal papers.

Extended summary:

Major accidents are characterized by complex causal patterns with many factors influencing the occurrence of such accidents. Within the offshore petroleum industry, the causes can be found not just in the execution of maintenance work, but also in the preparations and planning before performing the work. Planning of the work activities plays an important role in managing the activities and installation risk by identifying hazards and ensuring measures are planned for. One important basis for developing good plans and plan the work properly is to have the right information available at the right time in a format that facilitates understanding of important risk related aspects of the work. This paper presents a computerized display for a concept for how risk related information can be visualized in an operational context when establishing work orders. Design iterations have included participants from operating companies at the Norwegian continental shelf.

The starting point is that there are certain hazards, with associated probability and consequence that need to be managed. We identify relevant factors that influence risk and develop risk models to analyse risk. The output from this is a risk picture. This needs to be presented to the decision-makers (planners and others). Before a decision can be made, the information must be interpreted by the decision-makers and they should make sense of it within the context of the work that is going to take place. The focus in this paper is on the presentation of the information to the decision-makers.

Relevant information has been identified already in an earlier paper and the objective of this paper is primarily to investigate how we can present information about major accident risk in a manner that provides improved decision support in the planning process for activities on offshore oil and gas installations. The concept differentiates from traditional planning tools used by the operating companies and merges information from both planning, risk management and barrier management.

Thank you for your consideration.

Sincerely,

Sizarta Sarshar

*Senior Research Scientist, ICT Risk and Dependability
Software Engineering Department,
Sector for Safety Man-Technology Organisation,
Institute for Energy Technology (IFE)
P.B. 173. NO-1751 Halden, Norway
Mob.: +47 97 68 43 78
Email: sizarta.sarshar@ife.no*

Abstract

Major accidents are characterized by complex causal patterns with many factors influencing the occurrence of such accidents. Within the offshore petroleum industry the causes can be found not just in the execution of maintenance work, but also in the preparations and planning before performing the work. Planning of the work activities plays an important role in managing the activities and installation risk by identifying hazards and ensuring measures are planned for. One important basis for developing good plans and plan the work properly is to have the right information available at the right time in a format that facilitates understanding of important risk related aspects of the work. This paper presents a computerized display for a concept for how risk related information can be visualized in an operational context when establishing work orders. Design iterations have included participants from operating companies on the Norwegian continental shelf.

Visualizing risk related information for work orders through the planning process of maintenance activities

Sizarta Sarshar^{1,2} and Stein Haugen¹

¹Norwegian University of Science and Technology (NTNU), Trondheim, Norway

²Institute for Energy Technology (IFE), Halden, Norway

Emails:

Sizarta.sarshar@ife.no

Stein.haugen@ntnu.no

Acknowledgements

The authors wish to acknowledge the Norwegian Research Council for their financial support to the MIRMAP project, No. 228237/E30, funded by PETROMAKS2; the industry partners involved in the design process through workshop participation; and Lars Hurlen at IFE for internal review.

Visualizing risk related information for work orders through the planning process of maintenance activities

Abstract

Major accidents are characterized by complex causal patterns with many factors influencing the occurrence of such accidents. Within the offshore petroleum industry the causes can be found not just in the execution of maintenance work, but also in the preparations and planning before performing the work. Planning of the work activities plays an important role in managing the activities and installation risk by identifying hazards and ensuring measures are planned for. One important basis for developing good plans and plan the work properly is to have the right information available at the right time in a format that facilitates understanding of important risk related aspects of the work. This paper presents a computerized display for a concept for how risk related information can be visualized in an operational context when establishing work orders. Design iterations have included participants from operating companies on the Norwegian continental shelf.

1. Introduction

Planning of maintenance activities serves several purposes, of which the most obvious ones are to provide a basis for efficient performance of the activities with the time and resources available. However, in hazardous industries, maintenance planning also serves to manage risk, by identifying hazards and ensuring that measures are planned for that can contribute to reduce risk to an acceptable level. In the oil and gas industry offshore, evidence shows that there is significant scope for improvement in this area. Sarshar et al. (2015) looked at 24 investigation reports of gas leaks on the Norwegian Continental Shelf (NCS) and the review showed that in 18 of the cases, factors related to planning were identified as contributors to the incidents. An example includes that unoriginal parts were used for a job on a hydrocarbon leakage which caused a leak incident.

There can be many reasons why the planning process is not sufficient, but an important basis for developing good plans and making good decisions is clearly to have the right information available at the right time in a format that facilitates understanding of important risk related aspects of the work. Figure 1 gives an overview over the process. The starting point is that there are certain hazards, with associated probability and consequence that need to be managed. One identify relevant factors that influence risk and develop risk models to analyse risk. The output from this is a risk picture. In addition, Sarshar et al. (2017) also identified other relevant risk related information that is necessary to make good decision. This needs to be presented to the decision-makers (planners and others). Before a decision can be made, the information must be interpreted by the decision-makers and they have to make sense of it within the context of the work that is going to take place. The focus in this paper is on the presentation of the information to the decision-makers, or the visualization as it is described in the figure.

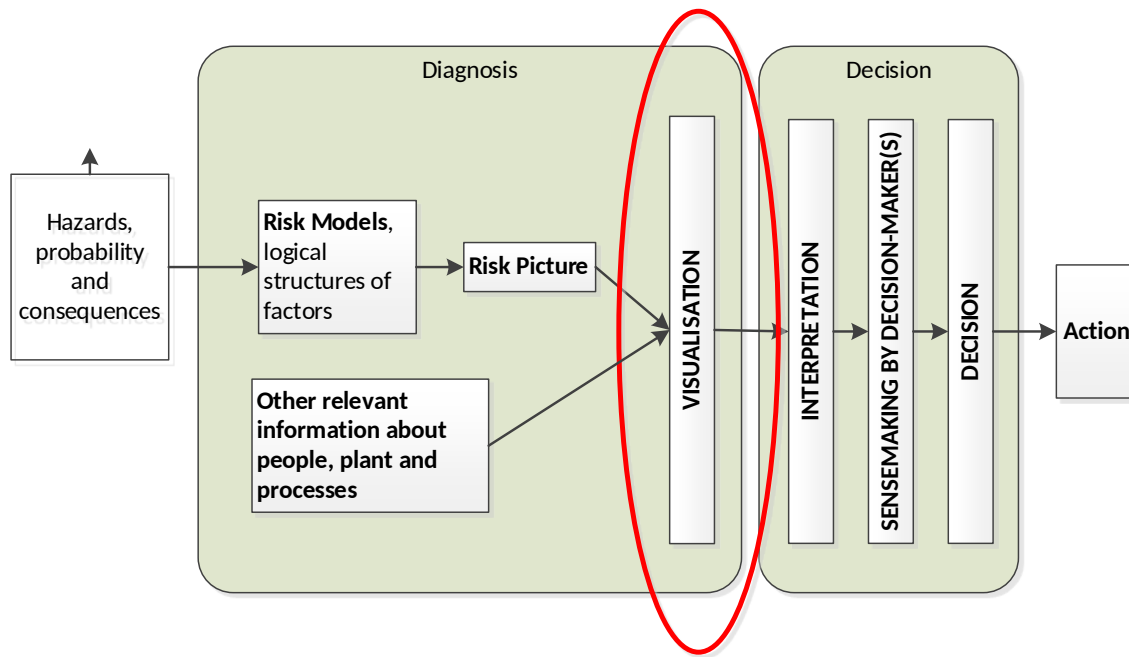

Figure 1: Diagnosis-Decision-Action (simplified version of figure from Albrechtsen et al., 2013)

Relevant information has been identified by Sarshar et al. (2017) and the objective of this paper is primarily to investigate how we can present information about major accident risk in a manner that provides improved decision support in the planning process for activities on offshore oil and gas installations.

The scope of this paper is limited to the establishment of work orders and their assessment. These steps are followed by assessment and approval of a work order plan which is then sent offshore for performance. Earlier planning stages and execution of the work that has been planned is not studied as such, although an important outcome of a good plan is its safe execution.

The rest of the paper is structured as follows. Section 2 provides background and discusses work related to the scope of this paper. Section 3 and 4 describes the approach and process for the study. Section 5 provides the main results of the concept developed. Section 6 concludes the work and comments on future work.

2. Background

Sarshar et al. (2015) identified several factors influencing major accident risk in the planning process that are related to information, e.g. «Information flow», «Communication» and «Misunderstandings». The challenges related to these were elaborated in a second paper (Sarshar et al., 2016). In a third paper (Sarshar et al., 2017), the authors moved into the topic of information in more detail, and looked specifically at what types of information are required to ensure that the best possible basis is available for making good decisions in the planning phase - to develop plans in which the risk for major accidents has been explicitly addressed. In this paper, we follow a design process to present the information in a manner that provides maximum support to the planning process and the decisions made in the planning process.

2.1 The planning process

A typical planning process offshore has been described in earlier papers (Sarshar et al., 2015; 2016; 2017). To provide the operational context for work orders a short description of the planning processes is provided.

Planning of maintenance and offshore operations can be divided in several phases spanning from several years to a daily plan. The planning is normally done by the onshore organisation and communicated to the offshore organisation which is responsible for execution of the plans, along with handling unplanned activities. The time horizon of the different plans spans from years to days. The main plan spans for a year, the operational plan for up to three months, the work order plan for up to two weeks and work permits are applied for before the job is executed the following day. To provide some context to work orders, the following operational planning steps are described related to the scope of this paper:

- *Establishing work orders.* Work orders are essentially descriptions of work that needs to be done in a plant. This is typically prepared by those that have technical responsibility for the plant and includes description of the work, when it needs to be done and resources required. In some cases, this can be done a long time before the work actually is performed, depending on the urgency of the work. Addressing major accident risk at this early stage can help to identify and manage critical aspects at an early stage.
- *Establishing a work order plan.* This implies piecing together a plan for all activities that will be performed within (typically) a two-week period. This takes the individual work orders as a starting point, with key constraints being available resources. From a risk point of view, the key concern is now whether the total risk level in any given period is too high and whether there are interactions between work orders (activities) that can increase risk.
- *Approving work permits.* Some of the operations or sub-activities that a work order consists of require work permits that need to be applied for and approved. Approval of work permits is the final stage in the planning process before execution. An approved work permit is necessary before an activity can be executed and the focus at this stage will be similar to the two above stages combined: Accepting that individual activities are safe to perform and that the total activity level on a given day is acceptable.

In this paper, we are focusing on what may be called operational planning decisions (Yang and Haugen, 2015). Decisions can be divided into planning decisions and execution decisions, where the main distinction lies in the time available for systematic comparison and evaluation of alternatives. Execution decisions are typically made purely on basis of experience, intuition and context, without careful evaluation of alternatives. This may be compared to “Fast thinking” decisions as described by Kahneman (2011). Planning decisions may also be based on the same background, applying “Fast thinking”, but at least time allows for more systematic analysis of alternatives.

2.2 Risk visualization as a tool

Based on our knowledge and experience through work with the petroleum industry operating at the NCS, most companies make use of separate tools and systems to manage different aspects of maintenance planning. Some operating companies have different software tools to manage the work activities in the different planning phases; different tools for managing barrier management, process and instrumentations diagrams, hazard analysis etc. These different systems often use tabular and

textual formats to present information. Using these tools do not necessarily mean that all necessary information is made available and is used in the different stages of the planning process.

On the work order level the attention is traditionally on scheduling and activity performance and little attention is given to their risk impact. While the intention of the planning process is to detail and deal with uncertainties as one plan towards execution at the sharp end, it seems like there is a break in continuity in the information flow from the operational plan to the work order plan (Sarshar et al, 2016). It is not until the work permit level that risk assessments are performed again.

Based on the outcome of Sarshar et al. (2017) there are areas where information systems can be improved to manage information through all planning phases:

- to assure transparency and flow of risk related information between the planning steps,
- to make information available at the planning step it is needed and in the context of the assessments it needs to support,
- to visualize and present the information in an intuitive way for the users to understand and interact with, and
- to support the plan and its risks to support decision making.

The objective of our visual design is to support the personnel involved in establishing and managing work orders and work permits in identifying potential hazards related to the activities planned. The intention is to present information in a way that raises questions about activities and the plans for discussion (alternatively; one could aim at developing a concept which provided a solution automatically). This requires mapping of the information to the decisions.

When presenting risk related information it is important that a risk is linked to its consequences to have a meaning. Consequences in narrative form are one form of visualization. A visual presentation of consequences will often generate a better insight than textual. Maps have been used for centuries to visualize spatial data. They help their users to better understand spatial relationships. From maps, information on distances, directions and area sizes can be retrieved, patterns revealed and relations understood (Kraak et al., 1996).

Eppler and Aeschmann (2008) describe that using visual metaphors have several distinct advantages when compared to typical diagrams or simple text: “They attract more and longer attention, they facilitate understanding by relating what is already known by the audience to unfamiliar information that is new and they are remembered better than text or diagrams, especially if the metaphor is unusual, but still fitting. As visual metaphors never perfectly fit the target domain, they also trigger sense making and discussions about the risks and the shortcomings of the chosen metaphor. In this way, they help to clarify risk understanding in groups by sparking lively debates.”

2.3 Context and information to present

The information required supporting the decision types can be structured in *activity* and *technical* related factors. The activity factors presents information which is valuable when establishing work, but also when assessing several activities in a plan. The technical factors present information on the status of the installation. The system information together with weather information and other operations at the installation form the operational context. Table 2 provides examples of some relevant activity and technical information to present regarding the work (Sarshar et al., 2017). However, the

information selected to be presented should support the decisions to be made and considered. A top-down approach is therefore important to guide the information selection process and good design principles to e.g. avoid information clutter.

Table 1: Relevant activity and technical information to present

Activity information	Technical information
<ul style="list-style-type: none"> • Description and steps • Work type, category, criticality and prioritization • Responsible technicians • Description of equipment: <ul style="list-style-type: none"> - Functional hierarchy - Documentation - Maintenance history • Resource needs <ul style="list-style-type: none"> - Expertise or other technicians - Isolation and blinding list - Scaffolding - Material movement on site - Crane operation - Area/process coordination - Production/CCR coordination • Applicable procedures • Tools required • Space required • Safe job analysis 	<ul style="list-style-type: none"> • Overview of installation, decks and modules <ul style="list-style-type: none"> - Zone classification - Noise classification - Crane reach area - Routes and emergency equipment - FAR/QRA data - Area specific hazards and risk • Overview of main equipment • Description of equipment <ul style="list-style-type: none"> - Criticality - Functional hierarchy - Documentation/specification - Maintenance history - Procedure for work - Special tool requirements - Equipment attributes (vibration, temp, etc.) • Process and instrumentation diagrams • Barriers and their status <ul style="list-style-type: none"> - Status of barriers for the installation - Weaknesses and degradations and their status • Deviations and their status

The information presented should among others support the following assessments related to identifying hazards during establishment of work order (ibid):

- Risk analysis of how activities or absence of activities can degrade the technical integrity.
- Risk analysis of how activity may influence or be influenced by area risk.
- Assessment of activities with respect to priority and criticality.
- Can activities introduce latent hazards?
- Are activities that take out or depend on barriers identified?
- Are adequate compensating measures identified and planned for?
- Are all resource needs identified?
- Are there critical human aspects of the work execution?
- Is there need for preparing SJA (Safe Job Analysis) from onshore?
- Does the activity require specific procedures, expertise, resources, isolation etc.?
- How does the activity affect the technical system, the area and other nearby activities?

We strive for a more thorough overview of activities and their hazards in our concept development and propose that the plan should be seen as a whole whenever possible and not divided in separated parts. This means that when e.g. a work order is established and assessed, its sub activities should be viewed in the same context as the work order. Such sub activities often require a work permit to execute and form the basis for these. The challenge is that they normally are viewed as a separate activity and when assessed, they are not assessed in the context of the work order. The result is that

information and hazards identified at the work order is not seemingly included when establishing and assessing the work permit.

2.4 Related design projects

There exist several research and commercial tools for supporting the planning process. The authors do not have extensive knowledge of all such tools, but are aware of some relevant projects that are briefly presented here. Lessons learned from these projects were used when developing the first visual design for the concept reported on in this paper. IOMAP (Integrated Operations Maintenance and modification Planner) was a prototype tool developed to promote risk-informed decision making by enabling earlier identification of risks by onshore staff when planning maintenance and modification tasks for offshore installations (Skjerve et al., 2011; Braseth and Sarshar, 2012). A thorough usability study was performed on the prototype with planners from the Norwegian Continental Shelf (NCS). A second version of the design was further developed by Braseth and Sarshar (2012). The intention was to study presentation of information about safety standards, job locations and occupational hazards in a way that supports identification of risks through pattern recognition and by highlighting key information. It makes use of a graphical map of the installation and presents the planned activities on top of it at their specific location. It presents calendar functionality and weather data. The planner can navigate through the different decks of the installation, and can also navigate through the different tasks planned for that 24-hour period.

A second prototype tool WISPI (Web based Information Surface for a Petroleum Installation) focused on visualizing activities planned for and in execution for a given day (Olsen et al., 2014; Sarshar et al., 2014). An excerpt of IOMAP and WISPI are illustrated in Figure 2. Scenario composer is another prototype tool developed to plan for personnel on board planning in relation to planned activities. This prototype has been further developed into a commercial tool applied for an operating company in Norway. Another operating company has developed their own tool for visualizing planned activities on platform drawings and include risk related information from QRA and area risk for their installations, and other companies are exploring such tools to better support their operations.

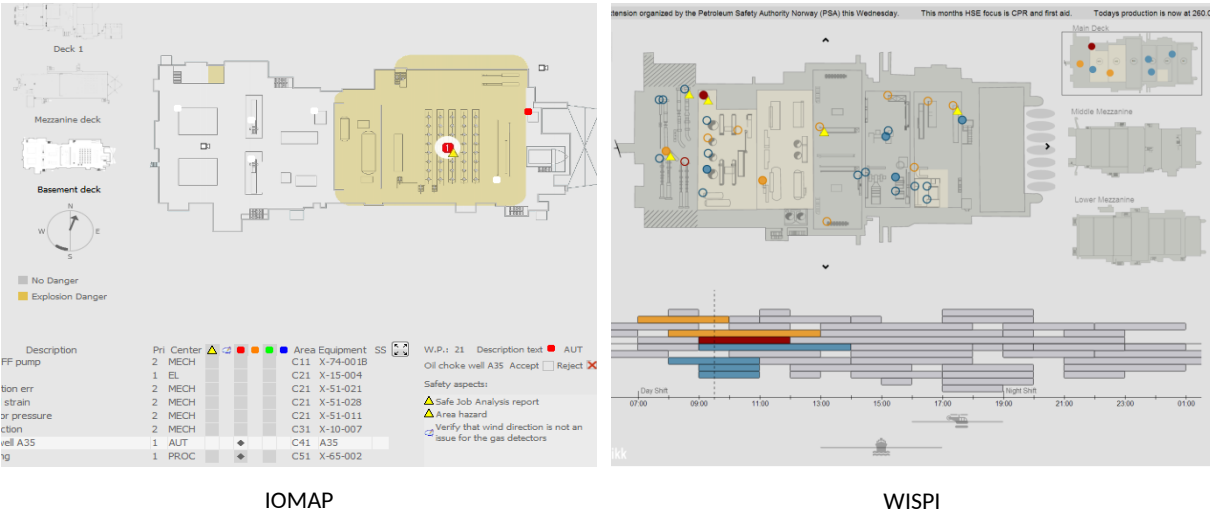

Figure 2: Excerpt of the IOMAP and WISPI research prototypes

3. Method

To develop a concept for risk visualization for the planning process an iterative design process was followed. First, what information is needed when in the planning process is defined through studies with industry involvement. An iterative design process is then followed to develop design concepts for how to visualize the information. The design ideas and proposals are assessed in cooperation with industry partners through the design cycles in form of workshops. Based on the iterations a final visual design is specified.

1. Step one is to set the objectives and requirements. Define context and information required to support decision making through the planning process. This was done through previous studies by Sarshar et al. (2013; 2015; 2016; 2017).
2. Step two is to describe the users and their information needs through user stories (Cohn, 2004), presented in Section 4.1. This requires identification of specific risk related information that is to support assessments and decisions to manage risk (based on Sarshar et al., 2017).
3. Step three is rapid concept development with assessment and detailing in cooperation with industry partners through multiple design cycles in form of workshops. The first version of the concept built on learning's from previous projects with visual design of similar concepts. Based on these learning's, a first visual design was developed to include the new information on activities and system aspects. The concept development was done with assessment and detailing in cooperation with industry partners through the workshops. There were three workshops in total with two different operating companies. This is presented in Section 4.2.
4. Step four was to specify the final visual design. This is presented in Section 5. The final design was presented to three different companies operating in the oil and gas industry in Norway. Their feedback is presented in section 5.

4. Design process

There is a large variety of personnel involved in the planning process, but they all share the common goal to prepare and perform the activities planned in a safe and efficient manner.

The concept developed in this paper focus only on assessment of work orders though it may also serve as a platform for work permits. The personnel involved in establishment and assessment of work orders are normally technical experts from the disciplines mechanic, electrician, automation and process engineer, personnel from technical integrity, maintenance and operation manager and the planner. They contribute with different expertise through different steps in the process. While the technicians often describe the work and involved steps, personnel from technical integrity and maintenance and operation manager verifies and adds on technical factors. Hazard identification is preferably performed by all who contribute in preparing the work.

4.1 User stories

To capture the human-computer interactions between the users and the visual concept, we focus on creating user stories. A user story normally includes a short and simple description of a feature perceived by a user following a simple template (Cohn, 2004).

Establishing user stories requires a breakdown of the considerations to be made in decision making to functionality and visualization needs. Excerpts of these are provided in Table 2. The first 10 are for a

user who establishes work orders while nr 11-13 is for a user who applies for work permits. The last column describes how the user needs are achieved in the developed concept which is presented in Section 5.

Table 2: User stories

ID	User stories	Achieved through
1	As a user who <i>establishes work orders</i> , I want to provide work description, so I can describe the work package.	The user can edit the description of a work order by defining the problem, how it shall be solved and the goal of solving the problem. Remarks may be provided and priority, start date and duration form part of the work order description.
2	...specify which equipment or system the work is on, so I can find relevant procedures, specifications and documentation.	The user specifies the equipment and the concept provides the system this is part of, its criticality, location on the installation and description. Applicable procedures for work on the equipment, checklists, specifications, pictures and other media are also listed.
3	...see the history of maintenance on the equipment, so I am up to date with the history.	The maintenance history is provided with the date for the maintenance activities, description and the technician responsible for it. The maintenance history is represented as a link so the user can navigate to the relevant work order to get more details
4	...see if any incidents have occurred with previous work on the system.	Together with the maintenance history, any incidents registered on the specific system are displayed with date and description.
5	...specify which work operations are required to perform the work package, so I can break down the work.	<p>A designated part of the display present all the sub activities of the work order with information of sequence, status, activity type, short description, responsible, estimated hours, resource needs, work type, required procedures and potential hazards.</p> <p>Several of these information fields are normally not specified at the work order level, but by providing it in the cases one have the information available, it will allow for earlier constrain and risk identification.</p>
6	...for each work operation be able to specify who is responsible for it, hours, resource needs, applicable procedures and work type, so I can better plan execution of each work operation.	<p>For each work operation, the user specifies its execution step (in sequence or parallel with the other operations), estimated hours for the operation, technician responsible, applicable procedures, work type, resource needs and whether it is planned carried out during daytime or night time.</p> <p>The concept allows the user to expand a work operation and get more details about it. This is displayed without jeopardizing what is already displayed and hence the user can assess the work operation in the context of the whole work package. Examples of such work operations can include setting isolation plan or a work permit to replace a valve.</p>
7	...specify hazards for the work operations, so I can mitigate them to avoid accidents.	A hazard table is provided to document hazards applicable to the work package. It consist of describing the hazard, the work operation and system it applies to, what causes it, its effect, proposed mitigation, barriers it affect, who is responsible for the mitigation and also whether the event of the hazard occurring trigger a major change so re-planning and reassessment is necessary. The concept allows hazards to be linked to the work operations so one can be more accurate on which hazards are applicable to which steps.

8	...specify which barriers that the work depends on (that must be in place), so I can plan for safe execution of the work.	There is field for specifying dependability to barriers and to support the process of identifying the relevant barriers: - the P&ID of the equipment and system the work applies to is presented
9	...specify which barriers this work degrade or take out, so barrier degradation is taking into consideration when approving the work.	- the location of work on the relevant level of the installation is presented - an overview of barrier functions for the specific equipment or system is presented
10	...know the status of barriers on the system I plan work for and in the area the work is to be executed, so I can identify potential hazards.	The status of the barriers on the system are provided through the P&ID, the location and barrier presentations by visual clues and metaphors representing e.g. diffuse leaks, temporary and permanent barrier degradations and dispensations from requirements.
11	As a user who <i>applies for work permits</i> , I want to build on the work order information when applying for work permit for one or several of the work operations, so I can have access to all work related information in one place and see the link between the operations in the work package	By selecting a work operation, the user gets the option to establish a work order for that operation. This allows to have the work permit information as part of the overall work order and one can consider the work permits in relation to all the work operations for the work order. As some operations do not require work permits (e.g. isolate the process equipment by applying the valve and blinding list), the relation between them is not easily visible with today's work permit systems. Here, these are all represented as part of the entire work order.
12	...have access to all previous assessments done with the work order, so I can be updated with previous steps	The history of the work order is displayed; such as when it was notified about need for work, planned, assessed, executed etc.
13	...specify work specific type and hazards, so I can document risk related aspects	The user can specify work permit attributes such as work type under the work operation and potential hazards in the hazard table of the visual display

These user stories are based on interviews with onshore and offshore personnel involved in the planning process, observations of different planning meetings onshore and offshore and workshops with industry partners. They represent general user stories for what establishment of work orders include and are not based on specific interviews with the aim of retrieving user stories.

4.2 Iterations

An overview of the concept development, main evaluation aspects and proposed improvements from the workshops are provided in Table 3. There were three workshops in total with two different operating companies.

Table 3: Concept description, evaluation and improvements of the design iterations

Iteration	Concept development	Evaluation	Improvements
1	Present important information to support establishment of work orders, link the activity to the equipment and include list of hazards and affected barriers. To support hazard identification and providing a visual representation of the work, the activities and hazards are visualized in a P&ID, area map and a barrier	Many of the information aspects presented are normally not used at the work order level, identifying the presented aspects earlier is very good. By visualizing this way several persons with less domain expertise can also contribute as it allows the user to easily relate to the work and the system the work applies	Add information of known incidents to the system.
Add reference to other planned work orders or events on the same system.			
Add temporary degradations and dispensations to the technical integrity on the visual representation of the map area.			

	overview.	to. <i>Evaluation by leader for operational plans and work orders.</i>	
2a	The equipment's maintenance history, incidents history and other planned work for are visualized using a timeline with the different events rather than listed textually.	It is very visual and effective to see all the events, history and planned work, for the equipment we plan work for. Brings to attention to dig into earlier events and check for coordination aspects for other planned work. All information presented is really good and necessary to support risk identification. The operational degradation causing diffuse discharges are good. To avoid many of the incidents we have experienced we need good tools to help us manage these (presented) data through such tools. <i>Evaluation by a platform manager.</i>	Highlight if there are planned (other) work on the blinds or valves involved in the isolation plan. Add technical degradations on the system, but also on other related systems nearby as is done for the firewall, e.g. corroded pipes or degraded shutdown function for parts of the system. Add safe job analysis as part of the hazard table.
2b		The inclusion of barrier information and the link between planning and barrier management is very interesting. <i>Evaluation by a process engineer.</i>	The historical timeline has a system/equipment perspective, one could also add activity aspects making us able to analyse what we went through; such as when it was notified about need for work, planned, assessed, executed etc.
3	Modified the timeline to also include activity history.		

4.3 Visualization

Eppler and Aeschmann (2008, p.26-27) present a set of guidelines to follow when attempting to visualize risks. These guidelines relate to the proper context of risk visualization, and the correct and user friendly visual rendering of risks. In Table 3 the guidelines are discussed in relation to our concept study. These and the design principles by Schneiderman (1983; 2010), Kraak et al. (1996), Ware (2008), Roth (2012) have been applied to the developed concept.

Table 4: Risk visualization guideline

Guideline	Concept study
<p>Don't precipitate the use of risk visualization. <i>Visualizations reify thoughts or opinions: Once something has been represented in an image, it is difficult to view it in another way. Thus carefully time the use of a graphic risk representation, as simple risk conversations can be more flexible than fixing them to an image too quickly.</i></p>	<p>In some cases one might want to wait showing a risk overview, and first collect individual opinions. In our concept the known technical hazards are visualized to help the user to identify how the work order may affect or be affected by these. The hazards represented are not to provide complete list of risks, rather to support risk identification.</p>

<p>Consider the application context and its constraints. <i>It is not always possible to make productive use of visualizations in risk management contexts because of lacking time, tools, or space. Thus, consider the time, resource and know-how constraints in a given situation and whether your audience would react positively to visualization or not. Visualizations may also detract attention from a presenter in a verbal communication setting. In addition, in inter-cultural risk committees the use of visuals may cause confusion because of differing expectations and conventions.</i></p>	<p>The concept, being a support tool to identify and manage hazards related to work order and work permits, is based on feedback from the workshops a way to present factual information and gathers experts to discuss potential hazards.</p>
<p>Make sure that the risk visualization respects the basic rules of visualization and perception.</p> <ul style="list-style-type: none"> - Items that are bigger should conceptually be more important or significant (as they attract more attention). - Items that are more centrally placed in a graphic are perceived to be more important than those at the periphery of a diagram. - Items that are placed close to one another are perceived to be similar or to be part of one group. - Visualize the same things with the same symbols and colours and different things differently. Use a consistent representation style. - Don't overload a diagram. Eliminate unnecessary elements whenever possible. - Time is usually mapped from left to right. - Provide a clear informative title for each diagram or map that indicates the so-what or key message it contains. 	<p>The concept developed tries to follow these basic laws of visual perception and the conventions of graphic design. As examples, the visual representation of the work order is the same symbol used in the timeline, P&ID and area view. The diagrams are simplified to avoid unnecessary elements.</p>
<p>Avoid decorative visualization without added benefit. <i>You should always check whether your risk visualizations add value, for example by making a risk easier to understand or assess, by communicating risk related information quicker or by being more memorable than text alone. You should also try to avoid unessential elements in a visualization, such as shading, borders, too many colours, animation effects, etc.</i></p>	<p>The hazards are both presented in table form (textual) and visual in the P&ID and are mapped when possible (given that they have a space or process relation that fits the diagrams).</p>
<p>Think visualizing, not visualization. <i>The power of visualization lies in its potential to surface implicit assumptions, capture different perspectives, and reveal new insights. This is especially true if visualization is used interactively by a group of managers and risk analysts. The process of creating and modifying a risk visualization is as important (if not more) as the final result.</i></p>	<p>Through all workshops and iterations with the design, the work has been presented as preliminary work in progress that invites for changes and modifications, rather than as a polished final product. The visualization has therefore been improved through the knowledge of the workshop participants.</p>
<p>Pre-test the risk visualization. <i>Have somebody who was not involved in the creation of the visualization give you spontaneous feedback on its comprehensibility.</i></p>	<p>The different iterations were discussed with colleagues not involved in the concept development process before they were used in the workshops with industry partners.</p>

Aggregating different data from different sources into one visual display is a challenging task. There are many pitfalls which can cause the user to be overflowed with information that would require high mental capability to digest and interpret.

The concept developed in our study is a visual concept (static) with no real user interaction as it is not a prototype. We apply the design principles described as best fits our purpose. The principle we aim for is to increase users' risk understanding through the visual representation of a work order and its context.

5. Results

The final design of the concept for work order visualization and interaction is presented in Figure 3. The screen consists of a part which contains information and descriptions about the work (left part) and a graphical part which present the work and its sub activities in process and instrumentation, plot and barrier diagrams (right part). The information provided is carefully selected to support risk identification and risk management through the planning of the work order activities.

The main new features of the concept include:

- Integrate the planning process with barrier management by presenting merged plan and risk related information.
- Visualise the work planned in the process and instrumentation diagram and area view simultaneously as all work descriptions, work operations and hazards are present.
- Present information about technical factors such as weaknesses and barrier status using visual clues in the process and instrumentation diagram and area view.
- Allow work operations to be assessed in the context of the entire work package as work operations are expanded and managed in the same view as for the work order.
- Allow for evaluating not only the specific equipment the work order applies to, but also e.g. equipment being part of the isolation plan (barriers) and their associated hazards and weaknesses.

The different parts of the concept are presented in the following. Though they are presented in separate parts, they are viewed together by the user and the different parts are linked and support each other. The work order used as case is related to replacing a valve that is leaking hydrocarbons. The illustrations and text used in the concept are for demonstration purposes only and do not represent a real system.

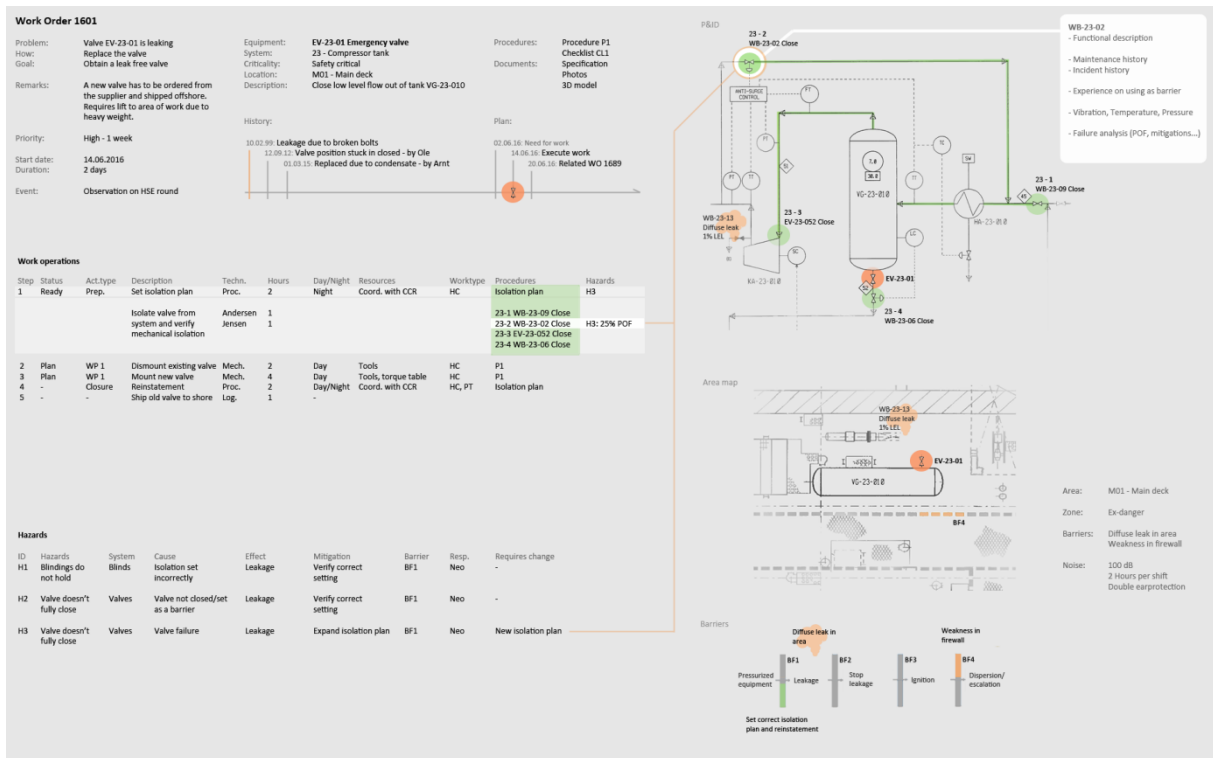

Figure 3: Concept for establishing and working on a work order

The left part of the display is further divided in three parts, work order and equipment description and history (Figure 4), work operations (Figure 5 and Figure 6) and hazards (Figure 7).

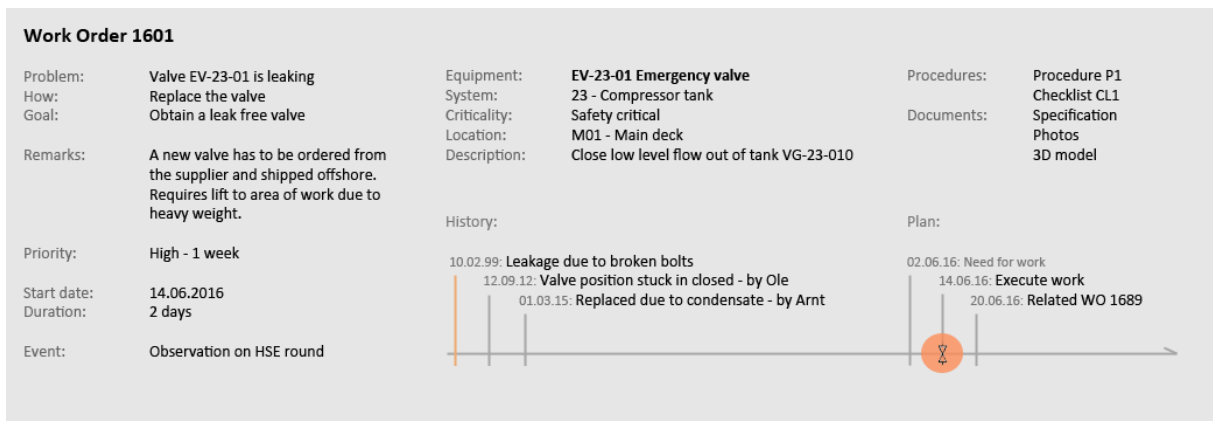

Figure 4: Work and equipment description and history

The work order and equipment description and history are illustrated in Figure 4. The work order description is provided as a problem statement, how the problem shall be solved and what the end goal of the work is. Remarks and comments are specified in a separate field from the problem statement. The priority, estimated start date, duration and how the need for work occurred (the event triggering it) are also provided. Next, when the equipment has been specified, the equipment name, the system it is part of, its criticality, location and description (purpose) is provided. In addition, applicable procedures for work on the equipment and specific technical documents are listed as links. These are meant to be gathered automatically by the system. Then a timeline is used to present history related to maintenance activities on the equipment and any incidents. In the example a leakage

incident that occurred in 1999 is marked in orange while the previous maintenance activities are marked in grey. To the right on the timeline the work order is displayed with the symbol of a valve on an orange circle. The orange colour is used to specify work on hydrocarbon carrying systems and is related to hydrocarbons. In addition to the specific work, future planned work on the same system that is already in the system is also displayed. The timeline allows the user to see the maintenance and incident history together with this and other planned activities on the system. This function is to our knowledge not part of existing systems used during planning of work orders or their operations.

Work operations										
Step	Status	Act.type	Description	Techn.	Hours	Day/Night	Resources	Worktype	Procedures	Hazards
1	Ready	Prep.	Set isolation plan	Proc.	2	Night	Coord. with CCR	HC	Isolation plan	H3
2	Plan	WP 1	Dismount existing valve	Mech.	2	Day	Tools	HC	P1	
3	Plan	WP 1	Mount new valve	Mech.	4	Day	Tools, torque table	HC	P1	
4	-	Closure	Reinstatement	Proc.	2	Day/Night	Coord. with CCR	HC, PT	Isolation plan	
5	-	-	Ship old valve to shore	Log.	1	-				

Figure 5: Work operations

The work operations are illustrated in Figure 5. Each line represents one sub activity. These are specified with their step number, status, activity type, short description, responsible technical discipline, estimated hours, whether it is to be performed during day or night shift offshore, resource needs, work type, required procedures and potential hazards. The work type is normally associated with the steps including work permit level 1. In this example HC is used as the acronym for work on hydrocarbon carrying system. The hazard field is a reference to the hazard table (Figure 7) where hazards for the specific step/sub activity are specified. Any of these work operations can be selected to expand additional information.

Work operations										
Step	Status	Act.type	Description	Techn.	Hours	Day/Night	Resources	Worktype	Procedures	Hazards
1	Ready	Prep.	Set isolation plan	Proc.	2	Night	Coord. with CCR	HC	Isolation plan	H3
			Isolate valve from system and verify mechanical isolation	Andersen Jensen	1 1				23-1 WB-23-09 Close 23-2 WB-23-02 Close 23-3 EV-23-052 Close 23-4 WB-23-06 Close	H3: 25% POF
2	Plan	WP 1	Dismount existing valve	Mech.	2	Day	Tools	HC	P1	
3	Plan	WP 1	Mount new valve	Mech.	4	Day	Tools, torque table	HC	P1	
4	-	Closure	Reinstatement	Proc.	2	Day/Night	Coord. with CCR	HC, PT	Isolation plan	
5	-	-	Ship old valve to shore	Log.	1	-				

Figure 6: Work operations - work operation one selected

Figure 6 illustrates the additional information for work operation one “set isolation plan”. A pattern layout (Meirelles, 2013) is used as visual mean so expanded information is an add-on to what was already displayed and not a replacement. The expanded information is located directly underneath the short information already visible. The description is more detailed; the responsible technical discipline is now specified with the personnel who is planned to do the job; the hours are divided among the personnel; the isolation plan is detailed with a list of which valves that must be set to open or closed position; and the hazard “H3” is further detailed to apply for the second step of the isolation plan. The description of hazard H3 is provided in the hazard table (Figure 7).

The intention is to use similar expansions to manage e.g. work permits which would be applicable to work operation two and three in the example. This would allow the work permit to be assessed in the context of the work order, as one of the work operations and with all the data already presented to be

applicable for all work operations. This function is to our knowledge not part of existing systems used during planning of work orders or their operations.

Hazards								
ID	Hazards	System	Cause	Effect	Mitigation	Barrier	Resp.	Requires change
H1	Blindings do not hold	Blinds	Isolation set incorrectly	Leakage	Verify correct setting	BF1	Neo	-
H2	Valve doesn't fully close	Valves	Valve not closed/set as a barrier	Leakage	Verify correct setting	BF1	Neo	-
H3	Valve doesn't fully close	Valves	Valve failure	Leakage	Expand isolation plan	BF1	Neo	New isolation plan

Figure 7: Hazards

The hazard overview is provided in Figure 7. Potential hazards are listed with an ID, description of the hazard, which system it applies to, what causes the hazard, its effect, mitigating measures, barriers it affects or is depending on, responsible personnel to follow up mitigations, and whether the occurrence of the hazard would require any change. In the example, hazard H2 and H3 are similar but have different causation. H2 is caused by the valve not being closed or that it is not correctly set as a barrier (some valves have special procedures for setting as a barrier compared to “simply” closing them). There may be many reasons why this could happen, human error during execution of the job being one of them. H3 on the other hand has valve failure as its cause. This is normally due to technical weakness of the design or degradation. If a pressure test unveils that the valve does not close properly, a required change in the plan might be to expand the isolation plan. For the work operation “set isolation plan” the hazard H3 is specified to apply to the valve WB-23-02 with 25% probability of failure (see Figure 6). The hazard H3 is also presented visually on the process and instrumentation diagram (Figure 8, upper left). This type of information is normally not available to the personnel involved in the planning process. Through this concept we illustrate one way it may be included to increase awareness of status and hazards associated to related equipment and systems to the equipment the work is planned on. One feedback from iteration two of the concept development was to include safe job analysis as part of the hazard table. Though this is not included in the example, the hazard table supports including aspects from safe job analysis.

The right part of the screen provides a visual presentation of the work and its sub activities in process and instrumentation (Figure 8), plot/area (Figure 9) and barrier (Figure 10) diagrams. The process and instrumentation diagram for the specific system is presented by the system (as illustrated in Figure 8) with the work order (applicable on valve EV-23-01) being displayed with orange circle around (the same way as was displayed at the timeline in Figure 4). When the isolation plan is specified, it can be presented in the same view. In this example the valves included in the isolation plan and the pipelines being isolated and which needs to be gas free are highlighted in green. Their IDs, names and position is also specified in the diagram. At the upper left part of the picture, the valve WB-23-02 has an orange circle around it. This is to highlight that the hazard H3 is applicable to this valve (see also Figure 6). Other weaknesses on the technical system that can be related to the diagram can also be visualized to provide the user with addition status and context. In this example there is a small diffuse leak at 1% LEL on WB-23-13. This is illustrated by an orange “cloud” at the left part of the picture. All parts of the diagram should be “clickable” so the user can get additional information about e.g. a specific piece of equipment. Such additional information could include functional description, maintenance and

incident history, experience setting it as a barrier, operation parameters (vibration, temperature, pressure, etc.), failure analysis (POF, mitigations, etc.).

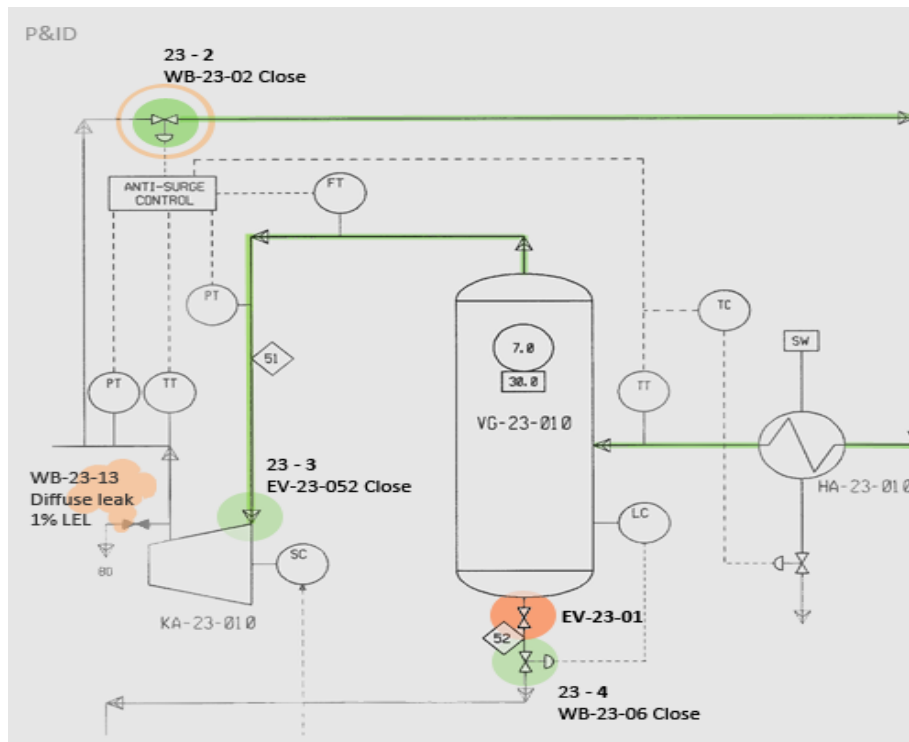

Figure 8: Process and instrumentation diagram

Figure 9 illustrates an area map of the facility where the work order takes place with the specific work order visualized using the same symbol as earlier. In addition, weaknesses and factors that may cause potential hazards can be presented given that they have a location which is nearby the work order. In this example the diffuse leak also presented on the P&ID is displayed. Another weakness presented is on a firewall with the title BF4 which is an acronym for Barrier Function 4 "Prevent dispersion and escalation". At the right part additional information of the area is provided including the area name, its zone classification, known weaknesses, noise level and requirements for work in the area.

When using maps, information can be presented in different layers. One could have background layers representing the noise level, zone classification, emergency pathways etc. These aspects have not been further developed in this concept.

The final part of the concept is a barrier overview specific to the work order. For a leakage scenario there are four main barrier functions in place: BF1 "Prevent leakage", BF2 "Contain leakage", BF3 "Prevent ignition" and BF4 "Prevent dispersion and escalation". Setting correct isolation contributes to strengthen BF1 and is here marked in green to give "credit" to plan for, set and reinstate the system correctly. The diffuse leakage is again displayed between BF1 and BF2. If execution of the work order would cause a leakage, the diffuse leak in the area is negligible. However, there are other activities that might be required as preparation in the area that should be aware of the diffuse leak, e.g. setting up scaffolding. The weakness in the firewall nearby the work area is highlighted in orange.

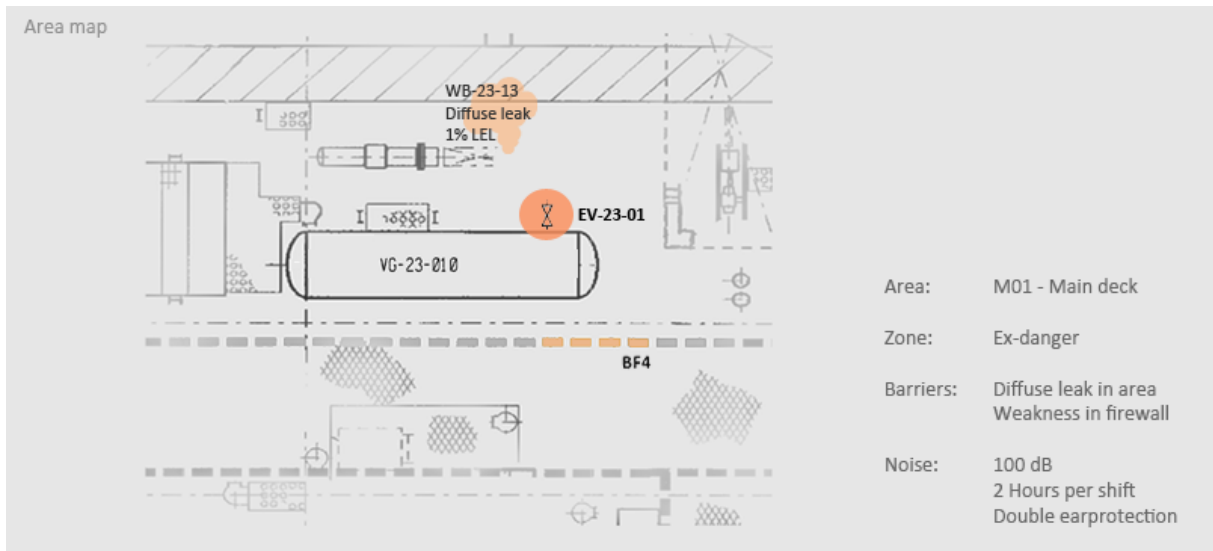

Figure 9: Area map

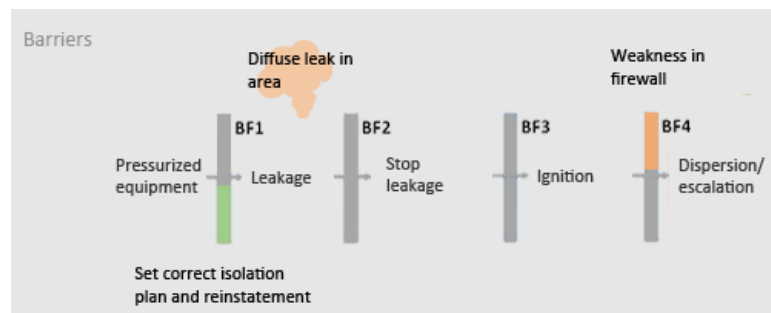

Figure 10: Barriers

All together, these different parts form the concept developed to present information in a way that may enhance hazard and risk identification.

6. Conclusions and further work

In this paper a concept for visualizing risk related to work orders has been developed. The focus has been on enabling the personnel involved in establishing and managing work orders to identify and manage hazards for major accidents. Based on feedback from the participants at the design iterations the concept is easy to understand and present very valuable information that is not normally available to them in their existing systems.

The final design of the concept study is based on the iterations with expert evaluations that was possible to perform during this study and is not meant to be a final product of any sort, it rather demonstrates how information can be aggregated from different sources (work order systems, barrier management systems, hazard and risk analysis, safe job analysis, etc.) and presented in a way that supports hazard identification and decision making processes related to managing work orders. Ideally, we would have run many more iterations and with personnel involved in establishing and assessing work orders and work permits to get an even better evaluated concept. Yet, the iterations we managed

to have through the workshops has highlighted the potential and needs for studying risk visualisation further.

The final design has been presented to three different companies operating in Norway with the following feedback summed up:

- The concept illustrates that it is possible to present a lot of valuable data in a single screen and in an understandable way.
- The concept provides good overview of work orders and their sub activities.
- The concept should allow for better hazard identification than systems in use today.
- Some operators have most of the data available, but in different systems and in other formats than presented here.

Some aspects that differentiate this concept from existing tools typically used by the operating companies include:

- Integrates the planning process with barrier management by visualizing the plan and barrier data in the same view and context
- Visualization of simultaneous operations and activities
- Provides context to the planned activities in contrast to SAP and other planning tools
- Can view all activities in the light of the work order
- Assess not only the equipment the work is on, but also associated and required equipment

The intention of this concept development has not been to make a product, rather to show how simple visualization means can help address and communicate risk related information through the planning process.

Further extension to the concept can include

- Visualizing critical human factors related to the work order steps, for example for verification and validation steps. For the work operation “set isolation plan” (Figure 6) a critical human task is to verify that the isolation is set according to the approved isolation plan. Similarly for verification of correct reinstatement before the process equipment is handed back to the central control room operators for e.g. production. For work on hydrocarbon carrying systems the isolation and reinstatement of the system are critical tasks that require verification of correct performance (NOG, 2013).
- Highlighting work activities and steps that deviate from procedures.
- Establishing an overview of a plan using the same design principles.

References

Albrechtsen, E., Grøtan, T.O., Haugen, S. (2013), Improving proactive major accident prevention by new technology and work processes, ESREL 2013, Amsterdam.

Braseth, A. O. and Sarshar, S. (2012), Improving Oil & Gas Installation Safety through Visualization of Risk Factors. In *Proceedings of the SPE Intelligent Energy International Conference*, 2012.

Cohn, M. (2004). *User Stories Applied: For Agile Software Development*, Pearson Education, ISBN 0-321-20568-5.

Eppler, M.J. and Aeschmann, M. (2008), *Envisioning Risk, A Systematic Framework for Risk Visualization in Risk Management and Communication*, ICA Working Paper 5/2008, Retrieved December 26, 2011, from <http://www.knowledge-communication.org/pdf/envisioning-risk.pdf>

Kahneman, D. (2011). *Thinking, fast and slow*. New York: Farrar, Straus and Giroux.

Kraak M.J., Ormeling F.J. and Ormeling, F. (1996), *Cartography: visualization of spatial data*.

Meirelles, I. (2013), *Design for information*, Rockport, ISBN 978-1-59253-806-5.

NOG (Norwegian Oil and Gas), 2013. *Best practice for isolation when working on hydrocarbon equipment: planning, isolation and reinstatement*.

Olsen, C. S., O. G. Nedrebø, P. J. Berg, J. M. Røsok, M. Eskerud, 2014. *Web based Information Surface for a Petroleum Installation*. Bachelor thesis, Østfold University College, 2014.

Roth, F. (2012), *Visualising Risk: The Use of Graphical Elements in Risk Analysis and Communication*, Center for Security Studies (CSS), ETH Zürich, 2012.

Sarshar, S., Haugen, S., Skjerve, A.B., 2017, Major accident decisions made through the planning process for offshore activities, *Manuscript submitted to Journal of Loss Prevention in the Process Industries* (20.02.2017).

Sarshar, S., Haugen, S., Skjerve, A.B., 2016, Challenges and proposals for managing major accident risk through the planning process, *Journal of Loss Prevention in the Process Industries* (2016), vol. 39, 93-105, doi: 10.1016/j.jlp.2015.11.012.

Sarshar, S., Haugen, S., Skjerve, A.B., 2015, Factors in offshore planning that affect the risk for major accidents, *Journal of Loss Prevention in the Process Industries* (2015), vol. 33, 188-199, doi:10.1016/j.jlp.2014.12.005.

Sarshar, S., Olsen, C.S., Røsok, J.M., Eskerud, M., Rindahl, G., Nedrebø, O.G., Berg, P.J., and Misund, G., 2014, Developing a shared information surface for offshore work permits, in *Proc. of Risk, Reliability and Societal Safety*, ESREL 2014, 14-18 September, Wroclaw, Poland, 2014.

Sarshar, S., Gran, B.A, Haugen, S., Skjerve, A.B., 2012, Visualisation of risk for hydrocarbon leakages in the planning of maintenance and modification activities on offshore petroleum installations, in *Proc. of Risk, Reliability and Societal Safety*, ESREL 2012.

Shneiderman, B., 2010, The eight golden rules of interface design, Retrieved June 28, 2016, from <https://www.cs.umd.edu/users/ben/goldenrules.html>

Shneiderman, B., 1983, *Direct manipulation: A step beyond programming languages*,

Skjerve, A.B., Sarshar, S., Rindahl, G., Braseth, A.O., Randem, H.O. and Fallmyr, O. (2011). *The Integrated Operations Maintenance and Modification Planner (IO-MAP) – The first usability evaluation – study and findings*. Center for Integrated Operations in the Petroleum Industry, Norway, 2011.

Yang, X., Haugen, S., 2015. Classification of risk to support decision-making in hazardous processes, *Journal of Safety Science* (2015), vol. 80, 115-126, doi:10.1016/j.ssci.2015.07.011.

Ware, C., 2008, *Visual Thinking for Design*, Elsevier Inc.